



## Vorläufiges NUTZWERTGUTACHTEN

für die Festsetzung der Nutzwerte und Mindestanteile der Wohnungen und sonstigen selbständigen Räumlichkeiten und über die auf der Liegenschaft vorhandenen Abstellplätze für Kraftfahrzeuge auf der Liegenschaft:

3107 St. Pölten, Dr. Wilhelm Steingötter-Straße 27  
Katastralgemeinde: 19594 Viehofen, Einlagezahl: 678  
Bezirksgericht: St. Pölten, Grundstück: 29/9

zum Zwecke der Begründung von Wohnungseigentum

im Sinne des § 9 Abs. 1 des Wohnungseigentumsgesetzes - WEG 2002 – idF der Wohnrechtsnovelle 2009 (WRN 2009) - BGBl. I Nr. 25/2009.

Architekt	Dipl.-Ing. Robert Angst	Austria	1020 Wien	Mayergasse 11
mobil: +43/(0)676/4340434	fax: +43/(0)1/21172-123	www.architekt-angst.at	office@architekt-angst.at	ATU
Bankverbindung	Ktonr.: 50144594400	Blz: 12000, BACA	IBAN: AT181200050144594400	BIC: BKAUATWW
Seite 1 von 84	NUTZWERTBERECHNUNG	6B47 STG27 GmbH&Co KG	GZ NW2105	04.07.2022



**Auftraggeber:**

**6B47 STG 27 GmbH & Co KG**  
**Heiligenstädter Lände 29**  
**1190 Wien**

**Wohnungseigentumstaugliche Objekte:**

**Auf gegenständlicher Liegenschaft befinden sich laut der Bescheinigung gemäß § 6 Abs. 2 Wohnungseigentumsgesetz - WEG 2002 - idF der Wohnrechtsnovelle 2009 (WRN 2009) - BGBl. Nr. 70/2002 idF BGBl. I Nr. 25/2009 folgende wohnungseigentumstaugliche Räumlichkeiten:**

**insgesamt: 399 wohnungseigentumstaugliche Objekte**

Aufgliederung laut Baubestand:

**191 Wohnung(en)**

**2 sonstige selbständige Räumlichkeit(en)**

**206 Abstellplatz (Abstellplätze) für Kraftfahrzeuge**

<b>Kategorie</b>	<b>Anzahl</b>	<b>hievon nicht bewertet</b>
Wohnungen	191	0
Geschäftslokale	2	0
Büros	0	0
Lager	0	0
Werkstätten	0	0
Ordinationen	0	0
Hotels / Pensionen / Restaurants	0	0
sonst. selbst. Räumlichkeiten	0	0
Abstellplatz (Abstellplätze) für Kraftfahrzeuge in der Tiefgarage	183	2
Abstellplatz (Abstellplätze) für Kraftfahrzeuge im Freien	23	2
Abstellplatz (Abstellplätze) für Kraftfahrzeuge in freistehenden Einzelgaragen	0	0
Abstellplatz (Abstellplätze) für Kraftfahrzeuge überdacht	0	0
Abstellplatz (Abstellplätze) für Kraftfahrzeuge im Doppelparker	0	0
Abstellplatz (Abstellplätze) für Kraftfahrzeuge in Garagen	0	0

**Allgemeinflächen**

Die Allgemeinflächen sind Flächen, die der allgemeinen Benützung dienen und an denen deshalb kein Nutzwert festgesetzt werden kann.

**Nutzflächenermittlung**

Die Nutzflächenermittlung erfolgte vom gef. Sachverständigen nach den Parifizierungsplänen mit den darin farblich dargestellten Wohnungen und der sonstigen selbständigen Räumlichkeit unter Zugrundelegung der in Rechtskraft erwachsenen Baubewilligung samt den bewilligten Bauplänen. Diese Nutzflächenermittlung ist integrierender Bestandteil des Gutachtens.



## Grundlagen:

- 1) Wohnungseigentumsgesetz 2002 (WEG 2002)
- 2) Beschein. gem. § 6 Abs.1 Ziff.2, WEG 2002 von Arch. Dipl.-Ing. Robert Angst
- 3) Empfehlungen Regelnutzwerte Zuschläge und Abstriche - Empfehlungen des Magistrats der Stadt Wien
- 4) Empfehlungen aus dem Fachbuch "Nutzfläche im Wohnrecht" - Böhm, Eckharter, Hauswirth, Heindl, Rollwagen
- 5) Die Nutzflächen sind aus den letztgültigen, baugenehmigten Plänen oder nach Naturmaßen ermittelt.
- 6) Grundbuchsauszug KG 19594 Viehofen, EZ 678 vom 22.6.2021
- 7) Die Einreichpläne von Architekten Maurer & Partner ZT GmbH, Kirchenplatz 3, 2020 Hollabrunn mit den Plannr.: 1876-A-G-G-999-001, 1876-A-G-G-099-011, 1876-A-G-G-099-012, 1876-A-G-G-100-011, 1876-A-G-G-100-012, 1876-A-G-G-101-011, 1876-A-G-G-102-011, 1876-A-G-G-103-011, 1876-A-G-G-104-011, 1876-A-G-G-105-011, 1876-A-G-G-106-011 vom 14.2.2020.
- 8) Die Planskizze mit der Nummerierung der Stellplätze im Freien
- 9) Aus den Verkaufsplänen wurden folgende Änderungen übernommen:

## Stiege 1

- Geschäftslokal: Bezeichnung statt Top S2.1, neu Top G-1, zusätzliche Freifläche, Raumbezeichnungen anders.
- Bei Top 177 wurden Flächenmäßig von den Einreichplänen auf die Flächen der Verkaufspläne geändert (Beilage 7).
- Bei 178 wurden Flächenmäßig von den Einreichplänen auf die Flächen der Verkaufspläne geändert (Beilage 8).
- Bei Top 146 statt wie bei den Einreichplänen nicht nur Loggia, sondern auch Balkon.
- Bei Top 148 statt wie bei den Einreichplänen nicht nur Loggia, sondern auch Balkon.
- Bei Top 145 statt wie bei den Einreichplänen nicht Loggia und Balkon, sondern nur Loggia.
- Bei Top 147 statt wie bei den Einreichplänen nicht Loggia und Balkon, sondern nur Loggia.
- Bei Top 176 und 177 statt wie bei den Einreichplänen nicht Loggia sondern Balkone.
- Bei Top 178 kommt ein Balkon gegenüber der Einreichung dazu.

## Stiege 2

- Geschäftslokal: Bezeichnung statt Top U1.1, neu Top G-2 , zusätzliche Freifläche, Raumbezeichnungen anders.
- Bei Top 206 statt wie bei den Einreichplänen nicht nur Loggia, sondern auch Balkon.
- Bei Top 207 statt wie bei den Einreichplänen nicht nur Loggia, sondern auch Balkon.
- Bei Top 213 statt wie bei den Einreichplänen nicht nur Loggia, sondern auch Balkon.
- Bei Top 214 statt wie bei den Einreichplänen nicht nur Loggia, sondern auch Balkon.



- Bei Top 220 statt wie bei den Einreichplänen nicht nur Loggia, sondern auch Balkon.
- Bei Top 221 statt wie bei den Einreichplänen nicht nur Loggia, sondern auch Balkon.
- Bei Top 227 statt wie bei den Einreichplänen nicht nur Loggia, sondern auch Balkon.
- Bei Top 228 statt wie bei den Einreichplänen nicht nur Loggia, sondern auch Balkon.

### **Erläuterungen:**

Ziel dieses Gutachtens ist die vorläufige Ermittlung der Nutzwerte und Mindestanteile an den wohnungseigentumstauglichen Objekten und den Abstellplätzen für Kraftfahrzeuge der gegenständlichen Liegenschaft zum Zwecke der Begründung von Wohnungseigentum.

Wohnungseigentum ist das dingliche, ausschließliche Verfügungs- und Nutzungsrecht an bestimmten Teilen der Liegenschaft (wohnungseigentumstauglichen Objekten sowie Abstellplätze für Kraftfahrzeuge), denen Selbständigkeit zukommt.

Diese liegt vor, wenn eine Benützung ohne Inanspruchnahme eines anderen Wohnungseigentumsobjektes möglich ist, und eine bauliche Abtrennung gegenüber anderen Objekten vorhanden ist. Mit derartigen selbständigen Einheiten können auch andere Teile der Liegenschaft als Zubehör im Wohnungseigentum stehen. An Teilen der Liegenschaft, die der allgemeinen Benützung dienen, kann Wohnungseigentum nicht begründet werden.

Gemäß § 8 (1) WEG 2002 idF WRN 2009 ist der Nutzwert einer Einheit in einer ganzen Zahl auszudrücken, wobei Teilbeträge unter 0,5 abgerundet und ab 0,5 aufgerundet werden. Die Berechnung erfolgt aus der Nutzfläche und aus Zuschlägen oder Abstrichen für Umstände, die nach der Verkehrsauffassung den Wert des Wohnungseigentumsobjektes erhöhen oder vermindern, wie etwa dessen Zweckbestimmung, Stockwerkslage, Lage innerhalb eines Stockwerks oder dessen Ausstattung mit offenen Balkonen, Terrassen und Zubehörobjekten im Sinne des § 2 Abs. 3 WEG 2002 idF WRN 2009.

Auch Zuschläge für die Ausstattung mit Zubehörobjekten im Sinne des § 2 Abs. 3 sowie mit offenen Balkonen und Terrassen sind in einer ganzen Zahl auszudrücken; es gilt die Rundungsbestimmung des Abs. 1 erster Satz. Der Zuschlag ist jedoch mindestens mit der Zahl Eins anzusetzen (§ 8 Abs. 2, Satz 1 WEG 2002 idF WRN 2009). Loggien, so vorhanden, werden mit 50 %, Wintergärten und Veranden mit 75 % des zugehörigen Wohnungsregelnutzwertes berücksichtigt.

Sofern Außenbereiche nur durch die Zuschlagsfläche eines Wohnungseigentumsobjektes begangen werden können und weder an ein anderes Wohnungseigentumsobjekt oder anderes nicht zugehöriges Wohnungseigentumszubehörsobjekt grenzen, wurden diese Bereiche ebenfalls als Zuschlagsfläche bewertet.

Sonstige werterhöhende oder wertvermindernde Unterschiede, die insgesamt nur einen Zuschlag oder Abstrich von nicht mehr als 2 vH rechtfertigen würden, sind zu vernachlässigen (§ 8 Abs. 2 WEG 2002 idF WRN 2009).

Gemäß § 8 (3) WEG 2002 idF WRN 2009 darf der Nutzwert eines Abstellplatzes für ein Kraftfahrzeug dessen Nutzfläche - außer zur Berücksichtigung von Zubehörobjekten - rechnerisch nicht übersteigen. Bei seiner Berechnung ist neben den in Abs. 1 genannten Umständen auch zu berücksichtigen, ob der Abstellplatz in einem Gebäude oder im Freien liegt, letzterenfalls ob er überdacht ist.



Der Mindestanteil, der zum Erwerb des Wohnungseigentums erforderlich ist, entspricht dem Verhältnis des Nutzwertes der einzelnen Einheit zum Nutzwert aller Einheiten und wird in einem diesbezüglichen Bruch ausgedrückt.

Der Regelnutzwert von 1,00 / m<sup>2</sup> wurde im vorliegenden Objekt mit Rücksicht auf die Lage und Art seiner Beschaffenheit für die im Obergeschoss 1 befindliche Wohnung TOP 106 angesetzt.

Bei Bestimmung der weiteren Nutzwerte wurde auf die Lage, den Ausbaugrad, Zweckbestimmung etc. der weiteren selbständigen Räumlichkeiten innerhalb der Liegenschaft Rücksicht genommen und daher die Unterschiede zur vorher genannten Wohnung im Verhältnis zum Regelnutzwert mit den entsprechenden Zuschlägen und Abstrichen (siehe Nutzwertberechnung) vorgenommen.

Die Nutzwerte wurden nach den Erfahrungen und mit Rücksicht auf die Zweckbestimmung der Räumlichkeiten als angemessen bestimmt.

Die Hausallgemeinteile werden den Beständen nicht als Zubehör zugerechnet und bleiben Allgemeinflächen ohne Begründung von Wohnungseigentum.

Da es sich um ein vorläufiges Gutachten handelt wurden teilweise Daten aus den Verkaufsplänen und diesem Gutachten angehängten Beilagen entnommen.

Aufgrund von allgemein zugänglichen E-Ladestation sollen folgende Stellplätze kein eibenes WE-Objekt werden, sondern Allgemeinteil sein: EG Stellplatz Nr. 19 + 20, UG Stellplatz Nr. 1-066 + 1-067.

Entgegen den unter Grundlagen Punkt 7 angeführten Plänen soll der ursprüngliche Paketraum im EG als WE-Zubehör (Lager) dem Geschäftslokal TOP G-1 zugeordnet werden.

Bei der Top 174 wird entgegen zum Einreichplan ein Teil der allgemeinen Gangfläche zum Vorraum zugeschlagen.



### Ermittlung der Abstriche und Zuschläge

	Empfehlung		von Nutzwert der Whg		Nutzwert/m <sup>2</sup>		Name
	von	bis	von	bis	von	bis	
<b>Stockwerkslage</b>							
Unterstes Wohngeschoss unter Niveau	-15,0%	-30,0%					A 1
Erdgeschoss an Straße	-5,0%	-15,0%					A 2
Erdgeschoss nicht unmittelbar an der Straße		-10,0%					A 3
Hochparterre an Straße		-10,0%					A 4
Hochparterre nicht unmittelbar an der Straße		-5,0%					A 5
Erster Stock	kA	kA					
Weitere Geschosse mit Lift	kA	kA					
Weitere Geschosse ohne Lift, je		-2,5%					A 6
Lage im Terrassengeschoss (Penthouse)		25,0%					Z 1
Nordlage		-5,0%					A 7
Lage über Durchfahrt/Durchgang		-5,0%					A 8
Lage über Müllraum		-5,0%					A 9
Lage unter Flachdach/Terrasse		-5,0%					A 10
<b>Reihen- oder Einfamilienhaus</b>							
Zuschlag falls auch Mehrwohnhäuser errichtet werden		10,0%					Z 2
<b>Ausstattungsunterschiede zur Vergleichswohnung</b>							
Zentral-, Etagen oder gleichwertige Heizung	-10,0%	10,0%					A 11/Z 3
Bade- oder Duschaum	-10,0%	10,0%					A 12/Z 4
weiteres Bad, je		5,0%					Z 5
weitere Dusche		2,5%					Z 6
WC im Wohnungsverband	-10,0%	10,0%					A 13/Z 7
weiteres WC im Wohnungsverband, je		5,0%					Z 8
Wasseranschluss im Wohnungsverband	-5,0%	5,0%					A 14/Z 9
Vorraum	-2,5%	2,5%					A 15/Z 10
Grundrisslösung	-10,0%	10,0%					A 16/Z 11
Gangküche	-5,0%						A 17
Kochnische bei Einzelraumwohnung	-5,0%						A 18
Bad und WC in einem Raum	-2,5%						A 19
schlechte Belichtung, z. B. Feuermauernähe, enge Höfe usw.	-5,0%						A 20
Dachgeschosswohnung (Abschlag für Dachschrägen)	-15,0%						A 21
Zuschlag für kleine Nutzfläche		30,0%					Z 12
Abschlag für große Nutzfläche	-20,0%						A 22
Loggia (Teil der Wohnnutzfläche)				50,0%			
Veranda (Teil der Wohnnutzfläche)				75,0%			
voll ausgestalteter Wintergarten (Teil der Wohnnutzfläche)				100,0%			
Zuschläge für Ausstattung mit Terrasse bzw. Balkon	2,5%	30,0%					Z 13
Zuschläge Bauteile auf/über fremdem Grund	2,5%	30,0%					Z 14
Substandardwohnung richtet sich nach Standard der Vergleichswhg							
bei Vergleichswohnung Kategorie A, Nutzfläche mind. 30 m <sup>2</sup>		-30,0%					A 23
bei Vergleichswohnung Kategorie B, zeitgemäße Badegelegenheit		-20,0%					A 24
bei Vergleichswohnung Kategorie C, WC und Wasser Innen		-10,0%					A 25
Geschäftsflächen/Ordination/Büro	0,0%	50,0%					Z 16
<b>Abstellplätze für KFZ</b>							
Abstellplatz in einem Gebäude					0,500	1,000	
Abstellplatz im Freien, nicht überdacht					0,250	0,500	
<b>Zubehörobjekte</b>							
Keller- und Dachbodenabteil, Kellerraum; Lattenverschlag						0,150	
Gartenfläche					0,050	0,100	
Terrassen und Balkone als Zubehör					0,150	0,250	

kA - keine Auswirkung



### Nutzflächen-/Nutzwertaufstellung:

Top Nummer	Raumbezeichn.	Lage	NFl. m <sup>2</sup>	bew. %	bew. m <sup>2</sup>	Regel NW	Zu-, Abschläge	NW/m <sup>2</sup>	NW	NW ges.
<b>Untergeschoss</b>										
Stellplatz 1-001	Garagenplatz KFZ	UG	12,50	100%	12,50	0,75		0,75	9	9
Stellplatz 1-001	<b>Mindestanteil: 9 von 14538</b>									
Stellplatz 1-002	Garagenplatz KFZ	UG	12,50	100%	12,50	0,75		0,75	9	9
Stellplatz 1-002	<b>Mindestanteil: 9 von 14538</b>									
Stellplatz 1-003	Garagenplatz KFZ	UG	12,50	100%	12,50	0,75		0,75	9	9
Stellplatz 1-003	<b>Mindestanteil: 9 von 14538</b>									
Stellplatz 1-004	Garagenplatz KFZ	UG	12,50	100%	12,50	0,75		0,75	9	9
Stellplatz 1-004	<b>Mindestanteil: 9 von 14538</b>									
Stellplatz 1-005	Garagenplatz KFZ	UG	12,50	100%	12,50	0,75		0,75	9	9
Stellplatz 1-005	<b>Mindestanteil: 9 von 14538</b>									
Stellplatz 1-006	Garagenplatz KFZ	UG	12,50	100%	12,50	0,75		0,75	9	9
Stellplatz 1-006	<b>Mindestanteil: 9 von 14538</b>									
Stellplatz 1-007	Garagenplatz KFZ	UG	12,50	100%	12,50	0,75		0,75	9	9
Stellplatz 1-007	<b>Mindestanteil: 9 von 14538</b>									
Stellplatz 1-008	Garagenplatz KFZ	UG	12,50	100%	12,50	0,75		0,75	9	9
Stellplatz 1-008	<b>Mindestanteil: 9 von 14538</b>									
Stellplatz 1-009	Garagenplatz KFZ	UG	12,50	100%	12,50	0,75		0,75	9	9
Stellplatz 1-009	<b>Mindestanteil: 9 von 14538</b>									
Stellplatz 1-010	Garagenplatz KFZ	UG	12,50	100%	12,50	0,75		0,75	9	9
Stellplatz 1-010	<b>Mindestanteil: 9 von 14538</b>									
Stellplatz 1-011	Garagenplatz KFZ	UG	12,50	100%	12,50	0,75		0,75	9	9
Stellplatz 1-011	<b>Mindestanteil: 9 von 14538</b>									
Stellplatz 1-012	Garagenplatz KFZ	UG	12,50	100%	12,50	0,75		0,75	9	9
Stellplatz 1-012	<b>Mindestanteil: 9 von 14538</b>									



Stellplatz 1-013	Garagenplatz KFZ	UG	12,50	100%	12,50	0,75			0,75	9	9
------------------	------------------	----	-------	------	-------	------	--	--	------	---	---

Stellplatz 1-013	Mindestanteil:	9	von	14538
------------------	----------------	---	-----	-------

Stellplatz 1-014	Garagenplatz KFZ	UG	12,50	100%	12,50	0,75			0,75	9	9
------------------	------------------	----	-------	------	-------	------	--	--	------	---	---

Stellplatz 1-014	Mindestanteil:	9	von	14538
------------------	----------------	---	-----	-------

Stellplatz 1-015	Garagenplatz KFZ	UG	12,50	100%	12,50	0,75			0,75	9	9
------------------	------------------	----	-------	------	-------	------	--	--	------	---	---

Stellplatz 1-015	Mindestanteil:	9	von	14538
------------------	----------------	---	-----	-------

Stellplatz 1-016	Garagenplatz KFZ	UG	12,50	100%	12,50	0,75			0,75	9	9
------------------	------------------	----	-------	------	-------	------	--	--	------	---	---

Stellplatz 1-016	Mindestanteil:	9	von	14538
------------------	----------------	---	-----	-------

Stellplatz 1-017	Garagenplatz KFZ	UG	12,50	100%	12,50	0,75			0,75	9	9
------------------	------------------	----	-------	------	-------	------	--	--	------	---	---

Stellplatz 1-017	Mindestanteil:	9	von	14538
------------------	----------------	---	-----	-------

Stellplatz 1-018	Garagenplatz KFZ	UG	12,50	100%	12,50	0,75			0,75	9	9
------------------	------------------	----	-------	------	-------	------	--	--	------	---	---

Stellplatz 1-018	Mindestanteil:	9	von	14538
------------------	----------------	---	-----	-------

Stellplatz 1-019	Garagenplatz KFZ	UG	12,50	100%	12,50	0,75			0,75	9	9
------------------	------------------	----	-------	------	-------	------	--	--	------	---	---

Stellplatz 1-019	Mindestanteil:	9	von	14538
------------------	----------------	---	-----	-------

Stellplatz 1-020	Garagenplatz KFZ	UG	12,50	100%	12,50	0,75			0,75	9	9
------------------	------------------	----	-------	------	-------	------	--	--	------	---	---

Stellplatz 1-020	Mindestanteil:	9	von	14538
------------------	----------------	---	-----	-------

Stellplatz 1-021	Garagenplatz KFZ	UG	12,50	100%	12,50	0,75			0,75	9	9
------------------	------------------	----	-------	------	-------	------	--	--	------	---	---

Stellplatz 1-021	Mindestanteil:	9	von	14538
------------------	----------------	---	-----	-------

Stellplatz 1-022	Garagenplatz KFZ	UG	12,50	100%	12,50	0,75			0,75	9	9
------------------	------------------	----	-------	------	-------	------	--	--	------	---	---

Stellplatz 1-022	Mindestanteil:	9	von	14538
------------------	----------------	---	-----	-------

Stellplatz 1-023	Garagenplatz KFZ	UG	12,50	100%	12,50	0,75			0,75	9	9
------------------	------------------	----	-------	------	-------	------	--	--	------	---	---

Stellplatz 1-023	Mindestanteil:	9	von	14538
------------------	----------------	---	-----	-------

Stellplatz 1-024	Garagenplatz KFZ	UG	12,50	100%	12,50	0,75			0,75	9	9
------------------	------------------	----	-------	------	-------	------	--	--	------	---	---

Stellplatz 1-024	Mindestanteil:	9	von	14538
------------------	----------------	---	-----	-------

Stellplatz 1-025	Garagenplatz KFZ	UG	12,50	100%	12,50	0,75			0,75	9	9
------------------	------------------	----	-------	------	-------	------	--	--	------	---	---

Stellplatz 1-025	Mindestanteil:	9	von	14538
------------------	----------------	---	-----	-------





Stellplatz 1-026	Garagenplatz KFZ	UG	12,50	100%	12,50	0,75			0,75	9	9
------------------	------------------	----	-------	------	-------	------	--	--	------	---	---

Stellplatz 1-026	Mindestanteil:	9	von	14538
------------------	----------------	---	-----	-------

Stellplatz 1-027	Garagenplatz KFZ	UG	12,50	100%	12,50	0,75			0,75	9	9
------------------	------------------	----	-------	------	-------	------	--	--	------	---	---

Stellplatz 1-027	Mindestanteil:	9	von	14538
------------------	----------------	---	-----	-------

Stellplatz 1-028	Garagenplatz KFZ	UG	12,50	100%	12,50	0,75			0,75	9	9
------------------	------------------	----	-------	------	-------	------	--	--	------	---	---

Stellplatz 1-028	Mindestanteil:	9	von	14538
------------------	----------------	---	-----	-------

Stellplatz 1-029	Garagenplatz KFZ	UG	12,50	100%	12,50	0,75			0,75	9	9
------------------	------------------	----	-------	------	-------	------	--	--	------	---	---

Stellplatz 1-029	Mindestanteil:	9	von	14538
------------------	----------------	---	-----	-------

Stellplatz 1-030	Garagenplatz KFZ	UG	12,50	100%	12,50	0,75			0,75	9	9
------------------	------------------	----	-------	------	-------	------	--	--	------	---	---

Stellplatz 1-030	Mindestanteil:	9	von	14538
------------------	----------------	---	-----	-------

Stellplatz 1-031	Garagenplatz KFZ	UG	12,50	100%	12,50	0,75			0,75	9	9
------------------	------------------	----	-------	------	-------	------	--	--	------	---	---

Stellplatz 1-031	Mindestanteil:	9	von	14538
------------------	----------------	---	-----	-------

Stellplatz 1-032	Garagenplatz KFZ	UG	12,50	100%	12,50	0,75			0,75	9	9
------------------	------------------	----	-------	------	-------	------	--	--	------	---	---

Stellplatz 1-032	Mindestanteil:	9	von	14538
------------------	----------------	---	-----	-------

Stellplatz 1-033	Garagenplatz KFZ	UG	12,50	100%	12,50	0,75			0,75	9	9
------------------	------------------	----	-------	------	-------	------	--	--	------	---	---

Stellplatz 1-033	Mindestanteil:	9	von	14538
------------------	----------------	---	-----	-------

Stellplatz 1-034	Garagenplatz KFZ	UG	12,50	100%	12,50	0,75			0,75	9	9
------------------	------------------	----	-------	------	-------	------	--	--	------	---	---

Stellplatz 1-034	Mindestanteil:	9	von	14538
------------------	----------------	---	-----	-------

Stellplatz 1-035	Garagenplatz KFZ	UG	12,50	100%	12,50	0,75			0,75	9	9
------------------	------------------	----	-------	------	-------	------	--	--	------	---	---

Stellplatz 1-035	Mindestanteil:	9	von	14538
------------------	----------------	---	-----	-------

Stellplatz 1-036	Garagenplatz KFZ	UG	12,50	100%	12,50	0,75			0,75	9	9
------------------	------------------	----	-------	------	-------	------	--	--	------	---	---

Stellplatz 1-036	Mindestanteil:	9	von	14538
------------------	----------------	---	-----	-------

Stellplatz 1-037	Garagenplatz KFZ	UG	12,50	100%	12,50	0,75			0,75	9	9
------------------	------------------	----	-------	------	-------	------	--	--	------	---	---

Stellplatz 1-037	Mindestanteil:	9	von	14538
------------------	----------------	---	-----	-------

Stellplatz 1-038	Garagenplatz KFZ	UG	12,50	100%	12,50	0,75			0,75	9	9
------------------	------------------	----	-------	------	-------	------	--	--	------	---	---

Stellplatz 1-038	Mindestanteil:	9	von	14538
------------------	----------------	---	-----	-------



Stellplatz 1-039	Garagenplatz KFZ	UG	12,50	100%	12,50	0,75			0,75	9	9
------------------	------------------	----	-------	------	-------	------	--	--	------	---	---

Stellplatz 1-039	Mindestanteil:	9	von	14538
------------------	----------------	---	-----	-------

Stellplatz 1-040	Garagenplatz KFZ	UG	12,50	100%	12,50	0,75			0,75	9	9
------------------	------------------	----	-------	------	-------	------	--	--	------	---	---

Stellplatz 1-040	Mindestanteil:	9	von	14538
------------------	----------------	---	-----	-------

Stellplatz 1-041	Garagenplatz KFZ	UG	12,50	100%	12,50	0,75			0,75	9	9
------------------	------------------	----	-------	------	-------	------	--	--	------	---	---

Stellplatz 1-041	Mindestanteil:	9	von	14538
------------------	----------------	---	-----	-------

Stellplatz 1-042	Garagenplatz KFZ	UG	12,50	100%	12,50	0,75			0,75	9	9
------------------	------------------	----	-------	------	-------	------	--	--	------	---	---

Stellplatz 1-042	Mindestanteil:	9	von	14538
------------------	----------------	---	-----	-------

Stellplatz 1-043	Garagenplatz KFZ	UG	12,50	100%	12,50	0,75			0,75	9	9
------------------	------------------	----	-------	------	-------	------	--	--	------	---	---

Stellplatz 1-043	Mindestanteil:	9	von	14538
------------------	----------------	---	-----	-------

Stellplatz 1-044	Garagenplatz KFZ	UG	12,50	100%	12,50	0,75			0,75	9	9
------------------	------------------	----	-------	------	-------	------	--	--	------	---	---

Stellplatz 1-044	Mindestanteil:	9	von	14538
------------------	----------------	---	-----	-------

Stellplatz 1-045	Garagenplatz KFZ	UG	12,50	100%	12,50	0,75			0,75	9	9
------------------	------------------	----	-------	------	-------	------	--	--	------	---	---

Stellplatz 1-045	Mindestanteil:	9	von	14538
------------------	----------------	---	-----	-------

Stellplatz 1-046	Garagenplatz KFZ	UG	12,50	100%	12,50	0,75			0,75	9	9
------------------	------------------	----	-------	------	-------	------	--	--	------	---	---

Stellplatz 1-046	Mindestanteil:	9	von	14538
------------------	----------------	---	-----	-------

Stellplatz 1-047	Garagenplatz KFZ	UG	12,50	100%	12,50	0,75			0,75	9	9
------------------	------------------	----	-------	------	-------	------	--	--	------	---	---

Stellplatz 1-047	Mindestanteil:	9	von	14538
------------------	----------------	---	-----	-------

Stellplatz 1-048	Garagenplatz KFZ	UG	12,50	100%	12,50	0,75			0,75	9	9
------------------	------------------	----	-------	------	-------	------	--	--	------	---	---

Stellplatz 1-048	Mindestanteil:	9	von	14538
------------------	----------------	---	-----	-------

Stellplatz 1-049	Garagenplatz KFZ	UG	12,50	100%	12,50	0,75			0,75	9	9
------------------	------------------	----	-------	------	-------	------	--	--	------	---	---

Stellplatz 1-049	Mindestanteil:	9	von	14538
------------------	----------------	---	-----	-------

Stellplatz 1-050	Garagenplatz KFZ	UG	12,50	100%	12,50	0,75			0,75	9	9
------------------	------------------	----	-------	------	-------	------	--	--	------	---	---

Stellplatz 1-050	Mindestanteil:	9	von	14538
------------------	----------------	---	-----	-------

Stellplatz 1-051	Garagenplatz KFZ	UG	12,50	100%	12,50	0,75			0,75	9	9
------------------	------------------	----	-------	------	-------	------	--	--	------	---	---

Stellplatz 1-051	Mindestanteil:	9	von	14538
------------------	----------------	---	-----	-------



Stellplatz 1-052	Garagenplatz KFZ	UG	12,50	100%	12,50	0,75			0,75	9	9
------------------	------------------	----	-------	------	-------	------	--	--	------	---	---

Stellplatz 1-052	Mindestanteil:	9	von	14538
------------------	----------------	---	-----	-------

Stellplatz 1-053	Garagenplatz KFZ	UG	12,50	100%	12,50	0,75			0,75	9	9
------------------	------------------	----	-------	------	-------	------	--	--	------	---	---

Stellplatz 1-053	Mindestanteil:	9	von	14538
------------------	----------------	---	-----	-------

Stellplatz 1-054	Garagenplatz KFZ	UG	12,50	100%	12,50	0,75			0,75	9	9
------------------	------------------	----	-------	------	-------	------	--	--	------	---	---

Stellplatz 1-054	Mindestanteil:	9	von	14538
------------------	----------------	---	-----	-------

Stellplatz 1-055	Garagenplatz KFZ	UG	12,50	100%	12,50	0,75			0,75	9	9
------------------	------------------	----	-------	------	-------	------	--	--	------	---	---

Stellplatz 1-055	Mindestanteil:	9	von	14538
------------------	----------------	---	-----	-------

Stellplatz 1-056	Garagenplatz KFZ	UG	12,50	100%	12,50	0,75			0,75	9	9
------------------	------------------	----	-------	------	-------	------	--	--	------	---	---

Stellplatz 1-056	Mindestanteil:	9	von	14538
------------------	----------------	---	-----	-------

Stellplatz 1-057	Garagenplatz KFZ	UG	12,50	100%	12,50	0,75			0,75	9	9
------------------	------------------	----	-------	------	-------	------	--	--	------	---	---

Stellplatz 1-057	Mindestanteil:	9	von	14538
------------------	----------------	---	-----	-------

Stellplatz 1-058	Garagenplatz KFZ	UG	12,50	100%	12,50	0,75			0,75	9	9
------------------	------------------	----	-------	------	-------	------	--	--	------	---	---

Stellplatz 1-058	Mindestanteil:	9	von	14538
------------------	----------------	---	-----	-------

Stellplatz 1-059	Garagenplatz KFZ	UG	12,50	100%	12,50	0,75			0,75	9	9
------------------	------------------	----	-------	------	-------	------	--	--	------	---	---

Stellplatz 1-059	Mindestanteil:	9	von	14538
------------------	----------------	---	-----	-------

Stellplatz 1-060	Garagenplatz KFZ	UG	12,50	100%	12,50	0,75			0,75	9	9
------------------	------------------	----	-------	------	-------	------	--	--	------	---	---

Stellplatz 1-060	Mindestanteil:	9	von	14538
------------------	----------------	---	-----	-------

Stellplatz 1-061	Garagenplatz KFZ	UG	12,50	100%	12,50	0,75			0,75	9	9
------------------	------------------	----	-------	------	-------	------	--	--	------	---	---

Stellplatz 1-061	Mindestanteil:	9	von	14538
------------------	----------------	---	-----	-------

Stellplatz 1-062	Garagenplatz KFZ	UG	12,50	100%	12,50	0,75			0,75	9	9
------------------	------------------	----	-------	------	-------	------	--	--	------	---	---

Stellplatz 1-062	Mindestanteil:	9	von	14538
------------------	----------------	---	-----	-------

Stellplatz 1-063	Garagenplatz KFZ	UG	12,50	100%	12,50	0,75			0,75	9	9
------------------	------------------	----	-------	------	-------	------	--	--	------	---	---

Stellplatz 1-063	Mindestanteil:	9	von	14538
------------------	----------------	---	-----	-------

Stellplatz 1-064	Garagenplatz KFZ	UG	12,50	100%	12,50	0,75			0,75	9	9
------------------	------------------	----	-------	------	-------	------	--	--	------	---	---

Stellplatz 1-064	Mindestanteil:	9	von	14538
------------------	----------------	---	-----	-------



Stellplatz 1-065	Garagenplatz KFZ	UG	12,50	100%	12,50	0,75			0,75	9	9
Stellplatz 1-065	Mindestanteil: 9 von 14538										
Stellplatz 1-068	Garagenplatz KFZ	UG	12,50	100%	12,50	0,75			0,75	9	9
Stellplatz 1-068	Mindestanteil: 9 von 14538										
Stellplatz 1-069	Garagenplatz KFZ	UG	12,50	100%	12,50	0,75			0,75	9	9
Stellplatz 1-069	Mindestanteil: 9 von 14538										
Stellplatz 1-070	Garagenplatz KFZ	UG	12,50	100%	12,50	0,75			0,75	9	9
Stellplatz 1-070	Mindestanteil: 9 von 14538										
Stellplatz 1-071	Garagenplatz KFZ	UG	12,50	100%	12,50	0,75			0,75	9	9
Stellplatz 1-071	Mindestanteil: 9 von 14538										
Stellplatz 1-072	Garagenplatz KFZ	UG	12,50	100%	12,50	0,75			0,75	9	9
Stellplatz 1-072	Mindestanteil: 9 von 14538										
Stellplatz 1-073	Garagenplatz KFZ	UG	12,50	100%	12,50	0,75			0,75	9	9
Stellplatz 1-073	Mindestanteil: 9 von 14538										
Stellplatz 1-074	Garagenplatz KFZ	UG	12,50	100%	12,50	0,75			0,75	9	9
Stellplatz 1-074	Mindestanteil: 9 von 14538										
Stellplatz 1-075	Garagenplatz KFZ	UG	12,50	100%	12,50	0,75			0,75	9	9
Stellplatz 1-075	Mindestanteil: 9 von 14538										
Stellplatz 1-076	Garagenplatz KFZ	UG	12,50	100%	12,50	0,75			0,75	9	9
Stellplatz 1-076	Mindestanteil: 9 von 14538										
Stellplatz 1-077	Garagenplatz KFZ	UG	12,50	100%	12,50	0,75			0,75	9	9
Stellplatz 1-077	Mindestanteil: 9 von 14538										
Stellplatz 1-078	Garagenplatz KFZ	UG	12,50	100%	12,50	0,75			0,75	9	9
Stellplatz 1-078	Mindestanteil: 9 von 14538										
Stellplatz 1-079	Garagenplatz KFZ	UG	12,50	100%	12,50	0,75			0,75	9	9
Stellplatz 1-079	Mindestanteil: 9 von 14538										



<b>Stellplatz 1-080</b>	Garagenplatz KFZ	UG	12,50	100%	<b>12,50</b>	0,75			0,75	9	9
<b>Stellplatz 1-080</b>	<b>Mindestanteil: 9 von 14538</b>										
<b>Stellplatz 1-081</b>	Garagenplatz KFZ	UG	12,50	100%	<b>12,50</b>	0,75			0,75	9	9
<b>Stellplatz 1-081</b>	<b>Mindestanteil: 9 von 14538</b>										
<b>Stellplatz 1-082</b>	Garagenplatz KFZ	UG	12,50	100%	<b>12,50</b>	0,75			0,75	9	9
<b>Stellplatz 1-082</b>	<b>Mindestanteil: 9 von 14538</b>										
<b>Stellplatz 1-083</b>	Garagenplatz KFZ	UG	12,50	100%	<b>12,50</b>	0,75			0,75	9	9
<b>Stellplatz 1-083</b>	<b>Mindestanteil: 9 von 14538</b>										
<b>Stellplatz 1-084</b>	Garagenplatz KFZ	UG	14,50	100%	<b>14,50</b>	0,75			0,75	11	11
<b>Stellplatz 1-084</b>	<b>Mindestanteil: 11 von 14538</b>										
<b>Stellplatz 1-085</b>	Garagenplatz KFZ	UG	14,50	100%	<b>14,50</b>	0,75			0,75	11	11
<b>Stellplatz 1-085</b>	<b>Mindestanteil: 11 von 14538</b>										
<b>Stellplatz 1-086</b>	Garagenplatz KFZ	UG	14,50	100%	<b>14,50</b>	0,75			0,75	11	11
<b>Stellplatz 1-086</b>	<b>Mindestanteil: 11 von 14538</b>										
<b>Stellplatz 1-087</b>	Garagenplatz KFZ	UG	14,50	100%	<b>14,50</b>	0,75			0,75	11	11
<b>Stellplatz 1-087</b>	<b>Mindestanteil: 11 von 14538</b>										
<b>Stellplatz 1-088</b>	Garagenplatz KFZ	UG	12,50	100%	<b>12,50</b>	0,75			0,75	9	9
<b>Stellplatz 1-088</b>	<b>Mindestanteil: 9 von 14538</b>										
<b>Stellplatz 1-089</b>	Garagenplatz KFZ	UG	12,50	100%	<b>12,50</b>	0,75			0,75	9	9
<b>Stellplatz 1-089</b>	<b>Mindestanteil: 9 von 14538</b>										
<b>Stellplatz 1-090</b>	Garagenplatz KFZ	UG	12,50	100%	<b>12,50</b>	0,75			0,75	9	9
<b>Stellplatz 1-090</b>	<b>Mindestanteil: 9 von 14538</b>										
<b>Stellplatz 1-091</b>	Garagenplatz KFZ	UG	12,50	100%	<b>12,50</b>	0,75			0,75	9	9
<b>Stellplatz 1-091</b>	<b>Mindestanteil: 9 von 14538</b>										
<b>Stellplatz 1-092</b>	Garagenplatz KFZ	UG	12,50	100%	<b>12,50</b>	0,75			0,75	9	9
<b>Stellplatz 1-092</b>	<b>Mindestanteil: 9 von 14538</b>										



Stellplatz 1-093	Garagenplatz KFZ	UG	12,50	100%	12,50	0,75			0,75	9	9
------------------	------------------	----	-------	------	-------	------	--	--	------	---	---

Stellplatz 1-093	Mindestanteil:	9	von	14538
------------------	----------------	---	-----	-------

Stellplatz 1-094	Garagenplatz KFZ	UG	12,50	100%	12,50	0,75			0,75	9	9
------------------	------------------	----	-------	------	-------	------	--	--	------	---	---

Stellplatz 1-094	Mindestanteil:	9	von	14538
------------------	----------------	---	-----	-------

Stellplatz 1-095	Garagenplatz KFZ	UG	12,50	100%	12,50	0,75			0,75	9	9
------------------	------------------	----	-------	------	-------	------	--	--	------	---	---

Stellplatz 1-095	Mindestanteil:	9	von	14538
------------------	----------------	---	-----	-------

Stellplatz 1-096	Garagenplatz KFZ	UG	12,50	100%	12,50	0,75			0,75	9	9
------------------	------------------	----	-------	------	-------	------	--	--	------	---	---

Stellplatz 1-096	Mindestanteil:	9	von	14538
------------------	----------------	---	-----	-------

Stellplatz 1-097	Garagenplatz KFZ	UG	12,50	100%	12,50	0,75			0,75	9	9
------------------	------------------	----	-------	------	-------	------	--	--	------	---	---

Stellplatz 1-097	Mindestanteil:	9	von	14538
------------------	----------------	---	-----	-------

Stellplatz 1-098	Garagenplatz KFZ	UG	12,50	100%	12,50	0,75			0,75	9	9
------------------	------------------	----	-------	------	-------	------	--	--	------	---	---

Stellplatz 1-098	Mindestanteil:	9	von	14538
------------------	----------------	---	-----	-------

Stellplatz 1-099	Garagenplatz KFZ	UG	12,50	100%	12,50	0,75			0,75	9	9
------------------	------------------	----	-------	------	-------	------	--	--	------	---	---

Stellplatz 1-099	Mindestanteil:	9	von	14538
------------------	----------------	---	-----	-------

Stellplatz 1-100	Garagenplatz KFZ	UG	12,50	100%	12,50	0,75			0,75	9	9
------------------	------------------	----	-------	------	-------	------	--	--	------	---	---

Stellplatz 1-100	Mindestanteil:	9	von	14538
------------------	----------------	---	-----	-------

Stellplatz 1-101	Garagenplatz KFZ	UG	12,50	100%	12,50	0,75			0,75	9	9
------------------	------------------	----	-------	------	-------	------	--	--	------	---	---

Stellplatz 1-101	Mindestanteil:	9	von	14538
------------------	----------------	---	-----	-------

Stellplatz 1-102	Garagenplatz KFZ	UG	12,50	100%	12,50	0,75			0,75	9	9
------------------	------------------	----	-------	------	-------	------	--	--	------	---	---

Stellplatz 1-102	Mindestanteil:	9	von	14538
------------------	----------------	---	-----	-------

Stellplatz 1-103	Garagenplatz KFZ	UG	12,50	100%	12,50	0,75			0,75	9	9
------------------	------------------	----	-------	------	-------	------	--	--	------	---	---

Stellplatz 1-103	Mindestanteil:	9	von	14538
------------------	----------------	---	-----	-------

Stellplatz 1-104	Garagenplatz KFZ	UG	12,50	100%	12,50	0,75			0,75	9	9
------------------	------------------	----	-------	------	-------	------	--	--	------	---	---

Stellplatz 1-104	Mindestanteil:	9	von	14538
------------------	----------------	---	-----	-------

Stellplatz 1-105	Garagenplatz KFZ	UG	14,50	100%	14,50	0,75			0,75	11	11
------------------	------------------	----	-------	------	-------	------	--	--	------	----	----

Stellplatz 1-105	Mindestanteil:	11	von	14538
------------------	----------------	----	-----	-------



<b>Stellplatz 1-106</b>	Garagenplatz KFZ	UG	14,50	100%	<b>14,50</b>	0,75			0,75	11	11
<b>Stellplatz 1-106</b>	<b>Mindestanteil: 11 von 14538</b>										
<b>Stellplatz 1-107</b>	Garagenplatz KFZ	UG	12,50	100%	<b>12,50</b>	0,75			0,75	9	9
<b>Stellplatz 1-107</b>	<b>Mindestanteil: 9 von 14538</b>										
<b>Stellplatz 1-108</b>	Garagenplatz KFZ	UG	12,50	100%	<b>12,50</b>	0,75			0,75	9	9
<b>Stellplatz 1-108</b>	<b>Mindestanteil: 9 von 14538</b>										
<b>Stellplatz 1-109</b>	Garagenplatz KFZ	UG	14,50	100%	<b>14,50</b>	0,75			0,75	11	11
<b>Stellplatz 1-109</b>	<b>Mindestanteil: 11 von 14538</b>										
<b>Stellplatz 1-110</b>	Garagenplatz KFZ	UG	14,50	100%	<b>14,50</b>	0,75			0,75	11	11
<b>Stellplatz 1-110</b>	<b>Mindestanteil: 11 von 14538</b>										
<b>Stellplatz 1-111</b>	Garagenplatz KFZ	UG	12,50	100%	<b>12,50</b>	0,75			0,75	9	9
<b>Stellplatz 1-111</b>	<b>Mindestanteil: 9 von 14538</b>										
<b>Stellplatz 1-112</b>	Garagenplatz KFZ	UG	12,50	100%	<b>12,50</b>	0,75			0,75	9	9
<b>Stellplatz 1-112</b>	<b>Mindestanteil: 9 von 14538</b>										
<b>Stellplatz 1-113</b>	Garagenplatz KFZ	UG	12,50	100%	<b>12,50</b>	0,75			0,75	9	9
<b>Stellplatz 1-113</b>	<b>Mindestanteil: 9 von 14538</b>										
<b>Stellplatz 1-114</b>	Garagenplatz KFZ	UG	12,50	100%	<b>12,50</b>	0,75			0,75	9	9
<b>Stellplatz 1-114</b>	<b>Mindestanteil: 9 von 14538</b>										
<b>Stellplatz 1-115</b>	Garagenplatz KFZ	UG	12,50	100%	<b>12,50</b>	0,75			0,75	9	9
<b>Stellplatz 1-115</b>	<b>Mindestanteil: 9 von 14538</b>										
<b>Stellplatz 1-116</b>	Garagenplatz KFZ	UG	12,50	100%	<b>12,50</b>	0,75			0,75	9	9
<b>Stellplatz 1-116</b>	<b>Mindestanteil: 9 von 14538</b>										
<b>Stellplatz 1-117</b>	Garagenplatz KFZ	UG	12,50	100%	<b>12,50</b>	0,75			0,75	9	9
<b>Stellplatz 1-117</b>	<b>Mindestanteil: 9 von 14538</b>										
<b>Stellplatz 1-118</b>	Garagenplatz KFZ	UG	12,50	100%	<b>12,50</b>	0,75			0,75	9	9
<b>Stellplatz 1-118</b>	<b>Mindestanteil: 9 von 14538</b>										



<b>Stellplatz 1-119</b>	Garagenplatz KFZ	UG	12,50	100%	<b>12,50</b>	0,75			0,75	9	9
<b>Stellplatz 1-119</b>	<b>Mindestanteil:</b>		<b>9</b>	<b>von</b>	<b>14538</b>						
<b>Stellplatz 1-120</b>	Garagenplatz KFZ	UG	12,50	100%	<b>12,50</b>	0,75			0,75	9	9
<b>Stellplatz 1-120</b>	<b>Mindestanteil:</b>		<b>9</b>	<b>von</b>	<b>14538</b>						
<b>Stellplatz 1-121</b>	Garagenplatz KFZ	UG	12,50	100%	<b>12,50</b>	0,75			0,75	9	9
<b>Stellplatz 1-121</b>	<b>Mindestanteil:</b>		<b>9</b>	<b>von</b>	<b>14538</b>						
<b>Stellplatz 1-122</b>	Garagenplatz KFZ	UG	12,50	100%	<b>12,50</b>	0,75			0,75	9	9
<b>Stellplatz 1-122</b>	<b>Mindestanteil:</b>		<b>9</b>	<b>von</b>	<b>14538</b>						
<b>Stellplatz 1-123</b>	Garagenplatz KFZ	UG	12,50	100%	<b>12,50</b>	0,75			0,75	9	9
<b>Stellplatz 1-123</b>	<b>Mindestanteil:</b>		<b>9</b>	<b>von</b>	<b>14538</b>						
<b>Stellplatz 1-124</b>	Garagenplatz KFZ	UG	12,50	100%	<b>12,50</b>	0,75			0,75	9	9
<b>Stellplatz 1-124</b>	<b>Mindestanteil:</b>		<b>9</b>	<b>von</b>	<b>14538</b>						
<b>Stellplatz 1-125</b>	Garagenplatz KFZ	UG	12,50	100%	<b>12,50</b>	0,75			0,75	9	9
<b>Stellplatz 1-125</b>	<b>Mindestanteil:</b>		<b>9</b>	<b>von</b>	<b>14538</b>						
<b>Stellplatz 1-126</b>	Garagenplatz KFZ	UG	13,80	100%	<b>13,80</b>	0,75			0,75	10	10
<b>Stellplatz 1-126</b>	<b>Mindestanteil:</b>		<b>10</b>	<b>von</b>	<b>14538</b>						
<b>Stellplatz 1-127</b>	Garagenplatz KFZ	UG	12,50	100%	<b>12,50</b>	0,75			0,75	9	9
<b>Stellplatz 1-127</b>	<b>Mindestanteil:</b>		<b>9</b>	<b>von</b>	<b>14538</b>						
<b>Stellplatz 1-128</b>	Garagenplatz KFZ	UG	12,50	100%	<b>12,50</b>	0,75			0,75	9	9
<b>Stellplatz 1-128</b>	<b>Mindestanteil:</b>		<b>9</b>	<b>von</b>	<b>14538</b>						
<b>Stellplatz 1-129</b>	Garagenplatz KFZ	UG	12,50	100%	<b>12,50</b>	0,75			0,75	9	9
<b>Stellplatz 1-129</b>	<b>Mindestanteil:</b>		<b>9</b>	<b>von</b>	<b>14538</b>						
<b>Stellplatz 1-130</b>	Garagenplatz KFZ	UG	12,50	100%	<b>12,50</b>	0,75			0,75	9	9
<b>Stellplatz 1-130</b>	<b>Mindestanteil:</b>		<b>9</b>	<b>von</b>	<b>14538</b>						
<b>Stellplatz 1-131</b>	Garagenplatz KFZ	UG	14,50	100%	<b>14,50</b>	0,75			0,75	11	11
<b>Stellplatz 1-131</b>	<b>Mindestanteil:</b>		<b>11</b>	<b>von</b>	<b>14538</b>						





<b>Stellplatz 1-132</b>	Garagenplatz KFZ	UG	14,50	100%	<b>14,50</b>	0,75			0,75	11	11
<b>Stellplatz 1-132</b>	<b>Mindestanteil: 11 von 14538</b>										
<b>Stellplatz 1-133</b>	Garagenplatz KFZ	UG	12,50	100%	<b>12,50</b>	0,75			0,75	9	9
<b>Stellplatz 1-133</b>	<b>Mindestanteil: 9 von 14538</b>										
<b>Stellplatz 1-134</b>	Garagenplatz KFZ	UG	12,50	100%	<b>12,50</b>	0,75			0,75	9	9
<b>Stellplatz 1-134</b>	<b>Mindestanteil: 9 von 14538</b>										
<b>Stellplatz 1-135</b>	Garagenplatz KFZ	UG	12,50	100%	<b>12,50</b>	0,75			0,75	9	9
<b>Stellplatz 1-135</b>	<b>Mindestanteil: 9 von 14538</b>										
<b>Stellplatz 1-136</b>	Garagenplatz KFZ	UG	12,50	100%	<b>12,50</b>	0,75			0,75	9	9
<b>Stellplatz 1-136</b>	<b>Mindestanteil: 9 von 14538</b>										
<b>Stellplatz 1-137</b>	Garagenplatz KFZ	UG	12,50	100%	<b>12,50</b>	0,75			0,75	9	9
<b>Stellplatz 1-137</b>	<b>Mindestanteil: 9 von 14538</b>										
<b>Stellplatz 1-138</b>	Garagenplatz KFZ	UG	12,50	100%	<b>12,50</b>	0,75			0,75	9	9
<b>Stellplatz 1-138</b>	<b>Mindestanteil: 9 von 14538</b>										
<b>Stellplatz 1-139</b>	Garagenplatz KFZ	UG	12,50	100%	<b>12,50</b>	0,75			0,75	9	9
<b>Stellplatz 1-139</b>	<b>Mindestanteil: 9 von 14538</b>										
<b>Stellplatz 1-140</b>	Garagenplatz KFZ	UG	12,50	100%	<b>12,50</b>	0,75			0,75	9	9
<b>Stellplatz 1-140</b>	<b>Mindestanteil: 9 von 14538</b>										
<b>Stellplatz 1-141</b>	Garagenplatz KFZ	UG	12,50	100%	<b>12,50</b>	0,75			0,75	9	9
<b>Stellplatz 1-141</b>	<b>Mindestanteil: 9 von 14538</b>										
<b>Stellplatz 1-142</b>	Garagenplatz KFZ	UG	12,50	100%	<b>12,50</b>	0,75			0,75	9	9
<b>Stellplatz 1-142</b>	<b>Mindestanteil: 9 von 14538</b>										
<b>Stellplatz 1-143</b>	Garagenplatz KFZ	UG	12,50	100%	<b>12,50</b>	0,75			0,75	9	9
<b>Stellplatz 1-143</b>	<b>Mindestanteil: 9 von 14538</b>										
<b>Stellplatz 1-144</b>	Garagenplatz KFZ	UG	12,50	100%	<b>12,50</b>	0,75			0,75	9	9
<b>Stellplatz 1-144</b>	<b>Mindestanteil: 9 von 14538</b>										



Stellplatz 1-145	Garagenplatz KFZ	UG	12,50	100%	12,50	0,75			0,75	9	9
------------------	------------------	----	-------	------	-------	------	--	--	------	---	---

Stellplatz 1-145	Mindestanteil:	9	von	14538
------------------	----------------	---	-----	-------

Stellplatz 1-146	Garagenplatz KFZ	UG	12,50	100%	12,50	0,75			0,75	9	9
------------------	------------------	----	-------	------	-------	------	--	--	------	---	---

Stellplatz 1-146	Mindestanteil:	9	von	14538
------------------	----------------	---	-----	-------

Stellplatz 1-147	Garagenplatz KFZ	UG	12,50	100%	12,50	0,75			0,75	9	9
------------------	------------------	----	-------	------	-------	------	--	--	------	---	---

Stellplatz 1-147	Mindestanteil:	9	von	14538
------------------	----------------	---	-----	-------

Stellplatz 1-148	Garagenplatz KFZ	UG	12,50	100%	12,50	0,75			0,75	9	9
------------------	------------------	----	-------	------	-------	------	--	--	------	---	---

Stellplatz 1-148	Mindestanteil:	9	von	14538
------------------	----------------	---	-----	-------

Stellplatz 1-149	Garagenplatz KFZ	UG	12,50	100%	12,50	0,75			0,75	9	9
------------------	------------------	----	-------	------	-------	------	--	--	------	---	---

Stellplatz 1-149	Mindestanteil:	9	von	14538
------------------	----------------	---	-----	-------

Stellplatz 1-150	Garagenplatz KFZ	UG	12,50	100%	12,50	0,75			0,75	9	9
------------------	------------------	----	-------	------	-------	------	--	--	------	---	---

Stellplatz 1-150	Mindestanteil:	9	von	14538
------------------	----------------	---	-----	-------

Stellplatz 1-151	Garagenplatz KFZ	UG	12,50	100%	12,50	0,75			0,75	9	9
------------------	------------------	----	-------	------	-------	------	--	--	------	---	---

Stellplatz 1-151	Mindestanteil:	9	von	14538
------------------	----------------	---	-----	-------

Stellplatz 1-152	Garagenplatz KFZ	UG	12,50	100%	12,50	0,75			0,75	9	9
------------------	------------------	----	-------	------	-------	------	--	--	------	---	---

Stellplatz 1-152	Mindestanteil:	9	von	14538
------------------	----------------	---	-----	-------

Stellplatz 1-153	Garagenplatz KFZ	UG	12,50	100%	12,50	0,75			0,75	9	9
------------------	------------------	----	-------	------	-------	------	--	--	------	---	---

Stellplatz 1-153	Mindestanteil:	9	von	14538
------------------	----------------	---	-----	-------

Stellplatz 1-154	Garagenplatz KFZ	UG	12,50	100%	12,50	0,75			0,75	9	9
------------------	------------------	----	-------	------	-------	------	--	--	------	---	---

Stellplatz 1-154	Mindestanteil:	9	von	14538
------------------	----------------	---	-----	-------

Stellplatz 1-155	Garagenplatz KFZ	UG	12,50	100%	12,50	0,75			0,75	9	9
------------------	------------------	----	-------	------	-------	------	--	--	------	---	---

Stellplatz 1-155	Mindestanteil:	9	von	14538
------------------	----------------	---	-----	-------

Stellplatz 1-156	Garagenplatz KFZ	UG	12,50	100%	12,50	0,75			0,75	9	9
------------------	------------------	----	-------	------	-------	------	--	--	------	---	---

Stellplatz 1-156	Mindestanteil:	9	von	14538
------------------	----------------	---	-----	-------

Stellplatz 1-157	Garagenplatz KFZ	UG	12,50	100%	12,50	0,75			0,75	9	9
------------------	------------------	----	-------	------	-------	------	--	--	------	---	---

Stellplatz 1-157	Mindestanteil:	9	von	14538
------------------	----------------	---	-----	-------



<b>Stellplatz 1-158</b>	Garagenplatz KFZ	UG	12,50	100%	<b>12,50</b>	0,75			0,75	9	9
<b>Stellplatz 1-158</b>	<b>Mindestanteil: 9 von 14538</b>										
<b>Stellplatz 1-159</b>	Garagenplatz KFZ	UG	12,50	100%	<b>12,50</b>	0,75			0,75	9	9
<b>Stellplatz 1-159</b>	<b>Mindestanteil: 9 von 14538</b>										
<b>Stellplatz 1-160</b>	Garagenplatz KFZ	UG	14,50	100%	<b>14,50</b>	0,75			0,75	11	11
<b>Stellplatz 1-160</b>	<b>Mindestanteil: 11 von 14538</b>										
<b>Stellplatz 1-161</b>	Garagenplatz KFZ	UG	14,50	100%	<b>14,50</b>	0,75			0,75	11	11
<b>Stellplatz 1-161</b>	<b>Mindestanteil: 11 von 14538</b>										
<b>Stellplatz 1-162</b>	Garagenplatz KFZ	UG	12,50	100%	<b>12,50</b>	0,75			0,75	9	9
<b>Stellplatz 1-162</b>	<b>Mindestanteil: 9 von 14538</b>										
<b>Stellplatz 1-163</b>	Garagenplatz KFZ	UG	12,50	100%	<b>12,50</b>	0,75			0,75	9	9
<b>Stellplatz 1-163</b>	<b>Mindestanteil: 9 von 14538</b>										
<b>Stellplatz 1-164</b>	Garagenplatz KFZ	UG	12,50	100%	<b>12,50</b>	0,75			0,75	9	9
<b>Stellplatz 1-164</b>	<b>Mindestanteil: 9 von 14538</b>										
<b>Stellplatz 1-165</b>	Garagenplatz KFZ	UG	12,50	100%	<b>12,50</b>	0,75			0,75	9	9
<b>Stellplatz 1-165</b>	<b>Mindestanteil: 9 von 14538</b>										
<b>Stellplatz 1-166</b>	Garagenplatz KFZ	UG	12,50	100%	<b>12,50</b>	0,75			0,75	9	9
<b>Stellplatz 1-166</b>	<b>Mindestanteil: 9 von 14538</b>										
<b>Stellplatz 1-167</b>	Garagenplatz KFZ	UG	12,50	100%	<b>12,50</b>	0,75			0,75	9	9
<b>Stellplatz 1-167</b>	<b>Mindestanteil: 9 von 14538</b>										
<b>Stellplatz 1-168</b>	Garagenplatz KFZ	UG	12,50	100%	<b>12,50</b>	0,75			0,75	9	9
<b>Stellplatz 1-168</b>	<b>Mindestanteil: 9 von 14538</b>										
<b>Stellplatz 1-169</b>	Garagenplatz KFZ	UG	12,50	100%	<b>12,50</b>	0,75			0,75	9	9
<b>Stellplatz 1-169</b>	<b>Mindestanteil: 9 von 14538</b>										
<b>Stellplatz 1-170</b>	Garagenplatz KFZ	UG	12,50	100%	<b>12,50</b>	0,75			0,75	9	9
<b>Stellplatz 1-170</b>	<b>Mindestanteil: 9 von 14538</b>										



Stellplatz 1-171	Garagenplatz KFZ	UG	12,50	100%	12,50	0,75			0,75	9	9
Stellplatz 1-171	Mindestanteil:		9	von	14538						
Stellplatz 1-172	Garagenplatz KFZ	UG	12,50	100%	12,50	0,75			0,75	9	9
Stellplatz 1-172	Mindestanteil:		9	von	14538						
Stellplatz 1-173	Garagenplatz KFZ	UG	12,50	100%	12,50	0,75			0,75	9	9
Stellplatz 1-173	Mindestanteil:		9	von	14538						
Stellplatz 1-174	Garagenplatz KFZ	UG	12,50	100%	12,50	0,75			0,75	9	9
Stellplatz 1-174	Mindestanteil:		9	von	14538						
Stellplatz 1-175	Garagenplatz KFZ	UG	12,50	100%	12,50	0,75			0,75	9	9
Stellplatz 1-175	Mindestanteil:		9	von	14538						
Stellplatz 1-176	Garagenplatz KFZ	UG	12,50	100%	12,50	0,75			0,75	9	9
Stellplatz 1-176	Mindestanteil:		9	von	14538						
Stellplatz 1-177	Garagenplatz KFZ	UG	12,50	100%	12,50	0,75			0,75	9	9
Stellplatz 1-177	Mindestanteil:		9	von	14538						
Stellplatz 1-178	Garagenplatz KFZ	UG	12,50	100%	12,50	0,75			0,75	9	9
Stellplatz 1-178	Mindestanteil:		9	von	14538						
Stellplatz 1-179	Garagenplatz KFZ	UG	12,50	100%	12,50	0,75			0,75	9	9
Stellplatz 1-179	Mindestanteil:		9	von	14538						
Stellplatz 1-180	Garagenplatz KFZ	UG	12,50	100%	12,50	0,75			0,75	9	9
Stellplatz 1-180	Mindestanteil:		9	von	14538						
Stellplatz 1-181	Garagenplatz KFZ	UG	12,50	100%	12,50	0,75			0,75	9	9
Stellplatz 1-181	Mindestanteil:		9	von	14538						
Stellplatz 1-182	Garagenplatz KFZ	UG	12,50	100%	12,50	0,75			0,75	9	9
Stellplatz 1-182	Mindestanteil:		9	von	14538						
Stellplatz 1-183	Garagenplatz KFZ	UG	12,50	100%	12,50	0,75			0,75	9	9
Stellplatz 1-183	Mindestanteil:		9	von	14538						



**Erdgeschoss**

<b>Stellplatz 1</b>	Stellplatz KFZ	EG	12,50	100%	<b>12,50</b>	0,50			0,50	6	6
<b>Stellplatz 1</b>	<b>Mindestanteil: 6 von 14538</b>										
<b>Stellplatz 2</b>	Stellplatz KFZ	EG	12,50	100%	<b>12,50</b>	0,50			0,50	6	6
<b>Stellplatz 2</b>	<b>Mindestanteil: 6 von 14538</b>										
<b>Stellplatz 3</b>	Stellplatz KFZ	EG	12,50	100%	<b>12,50</b>	0,50			0,50	6	6
<b>Stellplatz 3</b>	<b>Mindestanteil: 6 von 14538</b>										
<b>Stellplatz 4</b>	Stellplatz KFZ	EG	12,50	100%	<b>12,50</b>	0,50			0,50	6	6
<b>Stellplatz 4</b>	<b>Mindestanteil: 6 von 14538</b>										
<b>Stellplatz 5</b>	Stellplatz KFZ	EG	12,50	100%	<b>12,50</b>	0,50			0,50	6	6
<b>Stellplatz 5</b>	<b>Mindestanteil: 6 von 14538</b>										
<b>Stellplatz 6</b>	Stellplatz KFZ	EG	12,50	100%	<b>12,50</b>	0,50			0,50	6	6
<b>Stellplatz 6</b>	<b>Mindestanteil: 6 von 14538</b>										
<b>Stellplatz 7</b>	Stellplatz KFZ	EG	12,50	100%	<b>12,50</b>	0,50			0,50	6	6
<b>Stellplatz 7</b>	<b>Mindestanteil: 6 von 14538</b>										
<b>Stellplatz 8</b>	Stellplatz KFZ	EG	12,50	100%	<b>12,50</b>	0,50			0,50	6	6
<b>Stellplatz 8</b>	<b>Mindestanteil: 6 von 14538</b>										
<b>Stellplatz 9</b>	Stellplatz KFZ	EG	12,50	100%	<b>12,50</b>	0,50			0,50	6	6
<b>Stellplatz 9</b>	<b>Mindestanteil: 6 von 14538</b>										
<b>Stellplatz 10</b>	Stellplatz KFZ	EG	12,50	100%	<b>12,50</b>	0,50			0,50	6	6
<b>Stellplatz 10</b>	<b>Mindestanteil: 6 von 14538</b>										
<b>Stellplatz 11</b>	Stellplatz KFZ	EG	12,50	100%	<b>12,50</b>	0,50			0,50	6	6
<b>Stellplatz 11</b>	<b>Mindestanteil: 6 von 14538</b>										
<b>Stellplatz 12</b>	Stellplatz KFZ	EG	12,50	100%	<b>12,50</b>	0,50			0,50	6	6
<b>Stellplatz 12</b>	<b>Mindestanteil: 6 von 14538</b>										
<b>Stellplatz 13</b>	Stellplatz KFZ	EG	12,50	100%	<b>12,50</b>	0,50			0,50	6	6
<b>Stellplatz 13</b>	<b>Mindestanteil: 6 von 14538</b>										



<b>Stellplatz 14</b>	Stellplatz KFZ	EG	12,50	100%	<b>12,50</b>	0,50			0,50	6	6
----------------------	----------------	----	-------	------	--------------	------	--	--	------	---	---

<b>Stellplatz 14</b>	<b>Mindestanteil: 6 von 14538</b>
----------------------	-----------------------------------

<b>Stellplatz 15</b>	Stellplatz KFZ	EG	12,50	100%	<b>12,50</b>	0,50			0,50	6	6
----------------------	----------------	----	-------	------	--------------	------	--	--	------	---	---

<b>Stellplatz 15</b>	<b>Mindestanteil: 6 von 14538</b>
----------------------	-----------------------------------

<b>Stellplatz 16</b>	Stellplatz KFZ	EG	12,50	100%	<b>12,50</b>	0,50			0,50	6	6
----------------------	----------------	----	-------	------	--------------	------	--	--	------	---	---

<b>Stellplatz 16</b>	<b>Mindestanteil: 6 von 14538</b>
----------------------	-----------------------------------

<b>Stellplatz 17</b>	Stellplatz KFZ	EG	12,50	100%	<b>12,50</b>	0,50			0,50	6	6
----------------------	----------------	----	-------	------	--------------	------	--	--	------	---	---

<b>Stellplatz 17</b>	<b>Mindestanteil: 6 von 14538</b>
----------------------	-----------------------------------

<b>Stellplatz 18</b>	Stellplatz KFZ	EG	12,50	100%	<b>12,50</b>	0,50			0,50	6	6
----------------------	----------------	----	-------	------	--------------	------	--	--	------	---	---

<b>Stellplatz 18</b>	<b>Mindestanteil: 6 von 14538</b>
----------------------	-----------------------------------

<b>Stellplatz 21</b>	Stellplatz KFZ	EG	17,50	100%	<b>17,50</b>	0,50			0,50	9	9
----------------------	----------------	----	-------	------	--------------	------	--	--	------	---	---

<b>Stellplatz 21</b>	<b>Mindestanteil: 9 von 14538</b>
----------------------	-----------------------------------

<b>Stellplatz 22</b>	Stellplatz KFZ	EG	12,50	100%	<b>12,50</b>	0,50			0,50	6	6
----------------------	----------------	----	-------	------	--------------	------	--	--	------	---	---

<b>Stellplatz 22</b>	<b>Mindestanteil: 6 von 14538</b>
----------------------	-----------------------------------

<b>Stellplatz 23</b>	Stellplatz KFZ	EG	12,50	100%	<b>12,50</b>	0,50			0,50	6	6
----------------------	----------------	----	-------	------	--------------	------	--	--	------	---	---

<b>Stellplatz 23</b>	<b>Mindestanteil: 6 von 14538</b>
----------------------	-----------------------------------

## STIEGE 1

### Erdgeschoss

<b>Geschäft-TOP G-1</b>	<b>NFI.</b>		<b>235,29</b>		<b>235,29</b>	1,00	Z16(20%)	20,0%	1,20	282	
	Geschäft	EG	171,35	100%	171,35						
	Schleuse	EG	2,95	100%	2,95						
	WC/WR D	EG	5,73	100%	5,73						
	WC/WR H	EG	4,22	100%	4,22						
	Küche	EG	22,13	100%	22,13						
	Lage	EG	21,30	100%	21,30						
	Garderobe	EG	4,97	100%	4,97						
	WC Personal	EG	2,64	100%	2,64						
Zuschlag	<b>Terrasse</b>	EG	<b>96,22</b>		96,22		25% vom NW/m <sup>2</sup>		0,30	29	311
Zubehör	<b>Lager</b>	EG	<b>21,05</b>		21,05	0,80			0,80	17	17

<b>Geschäft-TOP G-1</b>	<b>Mindestanteil: 328 von 14538</b>
-------------------------	-------------------------------------



<b>Whg-TOP 101</b>	<b>NFI.</b>		<b>74,34</b>		<b>74,34</b>	1,00	A3(-5%)	-5,0%	0,95	71	
	VR	EG	8,63	100%	8,63						
	WC	EG	2,22	100%	2,22						
	Gang	EG	2,31	100%	2,31						
	AR	EG	1,69	100%	1,69						
	Bad	EG	5,47	100%	5,47						
	Zimmer 1	EG	12,11	100%	12,11						
	Zimmer 2	EG	15,12	100%	15,12						
	Wohnen	EG	21,97	100%	21,97						
	Kochen	EG	4,82	100%	4,82						
Zuschlag	<b>Terrasse</b>	EG	<b>8,74</b>		8,74		25% vom NW/m <sup>2</sup>		0,24	2	73
Zubehör	<b>Garten Top 101</b>	EG	<b>28,36</b>		28,36	0,10			0,10	3	3
<b>Whg-TOP 101</b>		<b>Mindestanteil:</b>		<b>76</b>	<b>von 14538</b>						

<b>Whg-TOP 102</b>			<b>48,12</b>		<b>45,80</b>	1,00	A3(-5%), A19(-2%)	-7,0%	0,93	43	
	VR	EG	4,34	100%	4,34						
	Bad	EG	6,00	100%	6,00						
	Zimmer	EG	11,18	100%	11,18						
	Wohnen	EG	16,86	100%	16,86						
	Kochen	EG	5,10	100%	5,10						
	<b>Loggia</b>	EG	<b>4,64</b>	50%	2,32						
Zuschlag	<b>Terrasse</b>	EG	<b>1,20</b>		1,20		25% vom NW/m <sup>2</sup>		0,23	1	44
Zubehör	<b>Garten Top 102</b>	EG	<b>22,23</b>		22,23	0,10			0,10	2	
Zubehör	<b>ER 2-1</b>	UG	<b>1,81</b>		1,81	0,30			0,30	1	3
<b>Whg-TOP 102</b>		<b>Mindestanteil:</b>		<b>47</b>	<b>von 14538</b>						

<b>Whg-TOP 103</b>			<b>48,12</b>		<b>45,80</b>	1,00	A3(-5%), A19(-2%)	-7,0%	0,93	43	
	VR	EG	4,34	100%	4,34						
	Bad	EG	6,00	100%	6,00						
	Zimmer	EG	11,18	100%	11,18						
	Wohnen	EG	16,86	100%	16,86						
	Kochen	EG	5,10	100%	5,10						
	<b>Loggia</b>	EG	<b>4,64</b>	50%	2,32						
Zuschlag	<b>Terrasse</b>	EG	<b>1,20</b>		1,20		25% vom NW/m <sup>2</sup>		0,23	1	44
Zubehör	<b>Garten Top 103</b>	EG	<b>22,23</b>		22,23	0,10			0,10	2	
Zubehör	<b>ER 2-2</b>	UG	<b>1,81</b>		1,81	0,30			0,30	1	3
<b>Whg-TOP 103</b>		<b>Mindestanteil:</b>		<b>47</b>	<b>von 14538</b>						



<b>Whg-TOP 104</b>	<b>NFI.</b>		<b>83,29</b>		<b>80,30</b>	1,00	A3(-5%)	-5,0%	0,95	76	
	VR	EG	5,92	100%	5,92						
	WC	EG	1,85	100%	1,85						
	Zimmer	EG	13,47	100%	13,47						
	Gang	EG	3,16	100%	3,16						
	AR	EG	2,27	100%	2,27						
	Bad	EG	6,96	100%	6,96						
	Schlafzimmer	EG	15,68	100%	15,68						
	Wohnen	EG	19,85	100%	19,85						
	Kochen	EG	8,15	100%	8,15						
	<b>Loggia</b>	EG	<b>5,98</b>	50%	2,99						
Zuschlag	<b>Terrasse</b>	EG	<b>1,53</b>		1,53		25% vom NW/m <sup>2</sup>		0,24	1	77
Zubehör	<b>Garten Top 104</b>	EG	<b>35,78</b>		35,78	0,10			0,10	4	4

<b>Whg-TOP 104</b>	<b>Mindestanteil:</b>	<b>81</b>	<b>von</b>	<b>14538</b>
--------------------	-----------------------	-----------	------------	--------------

#### Obergeschoß 1

<b>Whg-TOP 105</b>	<b>NFI.</b>		<b>41,70</b>		<b>41,70</b>	1,00	A8(-3%), A19(-2%)	-5,0%	0,95	40	
	VR	OG1	4,42	100%	4,42						
	Bad/WC	OG1	4,99	100%	4,99						
	Zimmer	OG1	11,11	100%	11,11						
	Wohnen	OG1	15,63	100%	15,63						
	Kochen	OG1	5,55	100%	5,55						
Zuschlag	<b>Balkon</b>	OG1	<b>5,86</b>		5,86		25% vom NW/m <sup>2</sup>		0,24	1	41
Zubehör	<b>ER 2-3</b>	UG	<b>1,81</b>		1,81	0,30			0,30	1	1

<b>Whg-TOP 105</b>	<b>Mindestanteil:</b>	<b>42</b>	<b>von</b>	<b>14538</b>
--------------------	-----------------------	-----------	------------	--------------

<b>Whg-TOP 106</b>	<b>NFI.</b>		<b>69,44</b>		<b>66,11</b>	1,00		0,0%	1,00	66	
	VR	OG1	3,09	100%	3,09						
	Gang	OG1	2,58	100%	2,58						
	AR	OG1	1,67	100%	1,67						
	WC	OG1	1,85	100%	1,85						
	Bad	OG1	6,16	100%	6,16						
	Zimmer 1	OG1	10,18	100%	10,18						
	Zimmer 2	OG1	10,71	100%	10,71						
	Wohnen	OG1	20,54	100%	20,54						
	Kochen	OG1	6,00	100%	6,00						
	<b>Loggia</b>	OG1	<b>6,66</b>	50%	3,33					66	
Zubehör	<b>ER 2-4</b>	UG	<b>1,81</b>		1,81	0,30			0,30	1	1

<b>Whg-TOP 106</b>	<b>Mindestanteil:</b>	<b>67</b>	<b>von</b>	<b>14538</b>
--------------------	-----------------------	-----------	------------	--------------

<b>Whg-TOP 107</b>	<b>NFI.</b>		<b>42,31</b>		<b>39,24</b>	1,00	A19(-2%)	-2,0%	0,98	38	
	VR/Kochen	OG1	7,23	100%	7,23						
	Bad	OG1	6,10	100%	6,10						
	Wohnen	OG1	22,84	100%	22,84						
	<b>Loggia</b>	OG1	<b>6,14</b>	50%	3,07					38	
Zubehör	<b>ER 2-5</b>	UG	<b>1,81</b>		1,81	0,30			0,30	1	1

<b>Whg-TOP 107</b>	<b>Mindestanteil:</b>	<b>39</b>	<b>von</b>	<b>14538</b>
--------------------	-----------------------	-----------	------------	--------------





<b>Whg-TOP 108</b>	<b>NFI.</b>		<b>74,53</b>		<b>70,81</b>	1,00		0,0%	1,00	71
	VR	OG1	7,74	100%	7,74					
	WC	OG1	1,85	100%	1,85					
	Gang	OG1	2,47	100%	2,47					
	Bad	OG1	4,63	100%	4,63					
	Zimmer 1	OG1	11,49	100%	11,49					
	Zimmer 2	OG1	10,57	100%	10,57					
	Wohnen	OG1	21,52	100%	21,52					
	Kochen	OG1	6,81	100%	6,81					
	<b>Loggia</b>	OG1	<b>7,45</b>	50%	3,73					71
Zubehör	<b>ER 2-6</b>	UG	<b>1,82</b>		1,82	0,30			0,30	1

<b>Whg-TOP 108</b>	<b>Mindestanteil:</b>	<b>72</b>	<b>von</b>	<b>14538</b>
--------------------	-----------------------	-----------	------------	--------------

<b>Whg-TOP 109</b>			<b>50,96</b>		<b>48,47</b>	1,00	A19(-2%)	-2,0%	0,98	48
	VR	OG1	4,77	100%	4,77					
	AR	OG1	1,47	100%	1,47					
	Bad/WC	OG1	5,73	100%	5,73					
	Zimmer	OG1	12,63	100%	12,63					
	Wohnen	OG1	17,78	100%	17,78					
	Kochen	OG1	3,60	100%	3,60					
	<b>Loggia</b>	OG1	<b>4,98</b>	50%	2,49					
Zuschlag	<b>Balkon</b>	OG1	<b>1,36</b>		1,36		25% vom NW/m <sup>2</sup>		0,25	1
Zubehör	<b>ER 4-1</b>	UG	<b>1,78</b>		1,78	0,30			0,30	1

<b>Whg-TOP 109</b>	<b>Mindestanteil:</b>	<b>50</b>	<b>von</b>	<b>14538</b>
--------------------	-----------------------	-----------	------------	--------------

<b>Whg-TOP 110</b>			<b>44,45</b>		<b>44,45</b>	1,00	A8(-3%), A19(-2%)	-5,0%	0,95	42
	Bad/WC	OG1	6,38	100%	6,38					
	Zimmer	OG1	11,59	100%	11,59					
	Wohnen	OG1	16,65	100%	16,65					
	Kochen	OG1	9,83	100%	9,83					
Zuschlag	<b>Balkon</b>	OG1	<b>6,82</b>		6,82		25% vom NW/m <sup>2</sup>		0,24	2
Zubehör	<b>ER 2-8</b>	UG	<b>1,75</b>		1,75	0,30			0,30	1

<b>Whg-TOP 110</b>	<b>Mindestanteil:</b>	<b>45</b>	<b>von</b>	<b>14538</b>
--------------------	-----------------------	-----------	------------	--------------

<b>Whg-TOP 111</b>			<b>44,83</b>		<b>44,83</b>	1,00	A9(-5%), A19(-2%)	-7,0%	0,93	42
	Bad/WC	OG1	6,38	100%	6,38					
	Zimmer	OG1	11,59	100%	11,59					
	Wohnen	OG1	16,89	100%	16,89					
	Kochen	OG1	9,97	100%	9,97					
Zuschlag	<b>Balkon</b>	OG1	<b>6,82</b>		6,82		25% vom NW/m <sup>2</sup>		0,23	2
Zubehör	<b>ER 2-9</b>	UG	<b>1,76</b>		1,76	0,30			0,30	1

<b>Whg-TOP 111</b>	<b>Mindestanteil:</b>	<b>45</b>	<b>von</b>	<b>14538</b>
--------------------	-----------------------	-----------	------------	--------------



<b>Whg-TOP 112</b>			<b>44,45</b>		<b>44,45</b>	1,00	A9(-5%), A19(-2%)	-7,0%	0,93	41	
	Bad/WC	OG1	6,38	100%	6,38						
	Zimmer	OG1	11,59	100%	11,59						
	Wohnen	OG1	16,65	100%	16,65						
	Kochen	OG1	9,83	100%	9,83						
Zuschlag	<b>Balkon</b>	OG1	<b>6,82</b>		6,82		25% vom NW/m <sup>2</sup>		0,23	2	43
Zubehör	<b>ER 2-10</b>	UG	<b>1,77</b>		1,77	0,30			0,30	1	1
<b>Whg-TOP 112</b>	<b>Mindestanteil:</b>		<b>44</b>	<b>von</b>	<b>14538</b>						

<b>Whg-TOP 113</b>			<b>44,45</b>		<b>44,45</b>	1,00	A19(-2%)	-2,0%	0,98	44	
	Bad/WC	OG1	6,38	100%	6,38						
	Zimmer	OG1	11,59	100%	11,59						
	Wohnen	OG1	16,65	100%	16,65						
	Kochen	OG1	9,83	100%	9,83						
Zuschlag	<b>Balkon</b>	OG1	<b>6,82</b>		6,82		25% vom NW/m <sup>2</sup>		0,25	2	46
Zubehör	<b>ER 2-11</b>	UG	<b>1,77</b>		1,77	0,30			0,30	1	1
<b>Whg-TOP 113</b>	<b>Mindestanteil:</b>		<b>47</b>	<b>von</b>	<b>14538</b>						

<b>Whg-TOP 114</b>	<b>NFI.</b>		<b>72,26</b>		<b>72,26</b>	1,00		0,0%	1,00	72	
	VR	OG1	6,57	100%	6,57						
	WC	OG1	1,85	100%	1,85						
	Zimmer 2	OG1	13,11	100%	13,11						
	Gang	OG1	2,12	100%	2,12						
	AR	OG1	1,20	100%	1,20						
	Bad	OG1	4,40	100%	4,40						
	Zimmer 1	OG1	11,56	100%	11,56						
	Wohnen	OG1	23,24	100%	23,24						
	Kochen	OG1	8,21	100%	8,21						
Zuschlag	<b>Balkon</b>	OG1	<b>6,82</b>		6,82		25% vom NW/m <sup>2</sup>		0,25	2	74
Zubehör	<b>ER 2-12</b>	UG	<b>1,78</b>		1,78	0,30			0,30	1	1
<b>Whg-TOP 114</b>	<b>Mindestanteil:</b>		<b>75</b>	<b>von</b>	<b>14538</b>						

<b>Whg-TOP 115</b>	<b>NFI.</b>		<b>84,63</b>		<b>80,99</b>	1,00		0,0%	1,00	81	
	VR	OG1	5,92	100%	5,92						
	WC	OG1	1,85	100%	1,85						
	Zimmer 2	OG1	13,47	100%	13,47						
	Gang	OG1	3,16	100%	3,16						
	AR	OG1	2,27	100%	2,27						
	Bad	OG1	7,00	100%	7,00						
	Zimmer 1	OG1	15,68	100%	15,68						
	Wohnen	OG1	19,85	100%	19,85						
	Kochen	OG1	8,15	100%	8,15						
	<b>Loggia</b>	OG1	<b>7,28</b>	50%	3,64						81
Zubehör	<b>ER 2-13</b>	UG	<b>1,80</b>		1,80	0,30			0,30	1	1
<b>Whg-TOP 115</b>	<b>Mindestanteil:</b>		<b>82</b>	<b>von</b>	<b>14538</b>						



<b>Whg-TOP 116</b>	<b>NFI.</b>		<b>48,12</b>		<b>45,80</b>	1,00	A19(-2%)	-2,0%	0,98	45	
	VR	OG1	4,34	100%	4,34						
	Bad/WC	OG1	6,00	100%	6,00						
	Zimmer	OG1	11,18	100%	11,18						
	Wohnen	OG1	16,86	100%	16,86						
	Kochen	OG1	5,10	100%	5,10						
	<b>Loggia</b>	OG1	<b>4,64</b>	50%	2,32						
Zuschlag	<b>Balkon</b>	OG1	<b>0,98</b>		0,98		25% vom NW/m <sup>2</sup>		0,25	1	46
Zubehör	<b>ER 2-14</b>	UG	<b>1,62</b>		1,62	0,30			0,30	1	1

<b>Whg-TOP 116</b>	<b>Mindestanteil:</b>	<b>47</b>	<b>von</b>	<b>14538</b>
--------------------	-----------------------	-----------	------------	--------------

<b>Whg-TOP 117</b>	<b>NFI.</b>		<b>49,13</b>		<b>46,31</b>	1,00	A19(-2%)	-2,0%	0,98	45	
	VR	OG1	4,34	100%	4,34						
	Bad/WC	OG1	6,00	100%	6,00						
	Zimmer	OG1	11,18	100%	11,18						
	Wohnen	OG1	16,86	100%	16,86						
	Kochen	OG1	5,10	100%	5,10						
	<b>Loggia</b>	OG1	<b>5,65</b>	50%	2,83					45	
Zubehör	<b>ER 2-15</b>	UG	<b>1,62</b>		1,62	0,30			0,30	1	1

<b>Whg-TOP 117</b>	<b>Mindestanteil:</b>	<b>46</b>	<b>von</b>	<b>14538</b>
--------------------	-----------------------	-----------	------------	--------------

<b>Whg-TOP 118</b>	<b>NFI.</b>		<b>48,12</b>		<b>45,80</b>	1,00	A19(-2%)	-2,0%	0,98	45	
	VR	OG1	4,34	100%	4,34						
	Bad/WC	OG1	6,00	100%	6,00						
	Zimmer	OG1	11,18	100%	11,18						
	Wohnen	OG1	16,86	100%	16,86						
	Kochen	OG1	5,10	100%	5,10						
	<b>Loggia</b>	OG1	<b>4,64</b>	50%	2,32						
Zuschlag	<b>Balkon</b>	OG1	<b>0,98</b>		0,98		25% vom NW/m <sup>2</sup>		0,25	1	46
Zubehör	<b>ER 2-16</b>	UG	<b>1,62</b>		1,62	0,30			0,30	1	1

<b>Whg-TOP 118</b>	<b>Mindestanteil:</b>	<b>47</b>	<b>von</b>	<b>14538</b>
--------------------	-----------------------	-----------	------------	--------------

<b>Whg-TOP 119</b>	<b>NFI.</b>		<b>48,76</b>		<b>45,93</b>	1,00	A8(-3%), A19(-2%)	-5,0%	0,95	44	
	VR	OG1	4,27	100%	4,27						
	Bad/WC	OG1	5,88	100%	5,88						
	Zimmer	OG1	10,99	100%	10,99						
	Wohnen	OG1	16,86	100%	16,86						
	Kochen	OG1	5,10	100%	5,10						
	<b>Loggia</b>	OG1	<b>5,66</b>	50%	2,83					44	
Zubehör	<b>ER 2-17</b>	UG	<b>1,62</b>		1,62	0,30			0,30	1	1

<b>Whg-TOP 119</b>	<b>Mindestanteil:</b>	<b>45</b>	<b>von</b>	<b>14538</b>
--------------------	-----------------------	-----------	------------	--------------



### Obergeschoß 2

Whg-TOP 120	NFI.		42,97		42,97	1,00	A19(-2%)	-2,0%	0,98	42	
	VR	OG2	4,40	100%	4,40						
	Bad/WC	OG2	5,20	100%	5,20						
	Zimmer	OG2	11,49	100%	11,49						
	Wohnen	OG2	16,33	100%	16,33						
	Kochen	OG2	5,55	100%	5,55						
Zuschlag	<b>Balkon</b>	OG2	<b>5,90</b>		5,90		25% vom NW/m <sup>2</sup>		0,25	1	43
Zubehör	<b>ER 2-18</b>	UG	<b>1,62</b>		1,62	0,30			0,30	1	1

<b>Whg-TOP 120</b>	<b>Mindestanteil:</b>	<b>44</b>	<b>von</b>	<b>14538</b>
--------------------	-----------------------	-----------	------------	--------------

Whg-TOP 121	NFI.		70,54		67,16	1,00		0,0%	1,00	67	
	VR	OG2	3,18	100%	3,18						
	Gang	OG2	2,58	100%	2,58						
	AR	OG2	1,67	100%	1,67						
	WC	OG2	1,85	100%	1,85						
	Bad	OG2	6,33	100%	6,33						
	Zimmer 1	OG2	10,32	100%	10,32						
	Zimmer 2	OG2	11,04	100%	11,04						
	Wohnen	OG2	20,81	100%	20,81						
	Kochen	OG2	6,00	100%	6,00						
	<b>Loggia</b>	OG2	<b>6,76</b>	50%	3,38					67	
Zubehör	<b>ER 2-19</b>	UG	<b>1,62</b>		1,62	0,30			0,30	1	1

<b>Whg-TOP 121</b>	<b>Mindestanteil:</b>	<b>68</b>	<b>von</b>	<b>14538</b>
--------------------	-----------------------	-----------	------------	--------------

Whg-TOP 122	NFI.		42,26		39,22	1,00	A19(-2%)	-2,0%	0,98	38	
	VR/Kochen	OG2	7,23	100%	7,23						
	Bad	OG2	6,10	100%	6,10						
	Wohnen	OG2	22,84	100%	22,84						
	<b>Loggia</b>	OG2	<b>6,09</b>	50%	3,05					38	
Zubehör	<b>ER 2-20</b>	UG	<b>1,67</b>		1,67	0,30			0,30	1	1

<b>Whg-TOP 122</b>	<b>Mindestanteil:</b>	<b>39</b>	<b>von</b>	<b>14538</b>
--------------------	-----------------------	-----------	------------	--------------

Whg-TOP 123	NFI.		75,80		72,08	1,00		0,0%	1,00	72	
	VR	OG2	7,90	100%	7,90						
	WC	OG2	1,85	100%	1,85						
	Gang	OG2	2,47	100%	2,47						
	Bad	OG2	4,73	100%	4,73						
	Zimmer 1	OG2	11,84	100%	11,84						
	Zimmer 2	OG2	10,90	100%	10,90						
	Wohnen	OG2	21,71	100%	21,71						
	Kochen	OG2	6,95	100%	6,95						
	<b>Loggia</b>	OG2	<b>7,45</b>	50%	3,73					72	
Zubehör	<b>ER 2-21</b>	KG	<b>1,61</b>		1,61	0,30			0,30	1	1

<b>Whg-TOP 123</b>	<b>Mindestanteil:</b>	<b>73</b>	<b>von</b>	<b>14538</b>
--------------------	-----------------------	-----------	------------	--------------



<b>Whg-TOP 124</b>			<b>51,99</b>		<b>49,50</b>	1,00	A19(-2%)	-2,0%	0,98	49	
	VR	OG2	4,85	100%	4,85						
	AR	OG2	1,54	100%	1,54						
	Bad/WC	OG2	5,87	100%	5,87						
	Zimmer	OG2	13,25	100%	13,25						
	Wohnen	OG2	17,74	100%	17,74						
	Kochen	OG2	3,76	100%	3,76						
	<b>Loggia</b>	OG2	<b>4,98</b>	50%	2,49						
Zuschlag	<b>Balkon</b>	OG2	<b>1,36</b>		1,36		25% vom NW/m <sup>2</sup>		0,25	1	50
Zubehör	<b>ER 4-2</b>	KG	<b>1,78</b>		1,78	0,30			0,30	1	1

<b>Whg-TOP 124</b>	<b>Mindestanteil:</b>	<b>51</b>	<b>von</b>	<b>14538</b>
--------------------	-----------------------	-----------	------------	--------------

<b>Whg-TOP 125</b>			<b>45,14</b>		<b>45,14</b>	1,00	A19(-2%)	-2,0%	0,98	44	
	Bad/WC	OG2	6,38	100%	6,38						
	Zimmer	OG2	11,72	100%	11,72						
	Wohnen	OG2	17,07	100%	17,07						
	Kochen	OG2	9,97	100%	9,97						
Zuschlag	<b>Balkon</b>	OG2	<b>6,82</b>		6,82		25% vom NW/m <sup>2</sup>		0,25	2	46
Zubehör	<b>ER 2-23</b>	KG	<b>1,62</b>		1,62	0,30			0,30	1	1

<b>Whg-TOP 125</b>	<b>Mindestanteil:</b>	<b>47</b>	<b>von</b>	<b>14538</b>
--------------------	-----------------------	-----------	------------	--------------

<b>Whg-TOP 126</b>			<b>45,14</b>		<b>45,14</b>	1,00	A19(-2%)	-2,0%	0,98	44	
	Bad/WC	OG2	6,38	100%	6,38						
	Zimmer	OG2	11,72	100%	11,72						
	Wohnen	OG2	17,07	100%	17,07						
	Kochen	OG2	9,97	100%	9,97						
Zuschlag	<b>Balkon</b>	OG2	<b>6,82</b>		6,82		25% vom NW/m <sup>2</sup>		0,25	2	46
Zubehör	<b>ER 2-24</b>	KG	<b>1,62</b>		1,62	0,30			0,30	1	1

<b>Whg-TOP 126</b>	<b>Mindestanteil:</b>	<b>47</b>	<b>von</b>	<b>14538</b>
--------------------	-----------------------	-----------	------------	--------------

<b>Whg-TOP 127</b>			<b>45,14</b>		<b>45,14</b>	1,00	A19(-2%)	-2,0%	0,98	44	
	Bad/WC	OG2	6,38	100%	6,38						
	Zimmer	OG2	11,72	100%	11,72						
	Wohnen	OG2	17,07	100%	17,07						
	Kochen	OG2	9,97	100%	9,97						
Zuschlag	<b>Balkon</b>	OG2	<b>6,82</b>		6,82		25% vom NW/m <sup>2</sup>		0,25	2	46
Zubehör	<b>ER 2-25</b>	KG	<b>1,62</b>		1,62	0,30			0,30	1	1

<b>Whg-TOP 127</b>	<b>Mindestanteil:</b>	<b>47</b>	<b>von</b>	<b>14538</b>
--------------------	-----------------------	-----------	------------	--------------

<b>Whg-TOP 128</b>			<b>45,14</b>		<b>45,14</b>	1,00	A19(-2%)	-2,0%	0,98	44	
	Bad/WC	OG2	6,38	100%	6,38						
	Zimmer	OG2	11,72	100%	11,72						
	Wohnen	OG2	17,07	100%	17,07						
	Kochen	OG2	9,97	100%	9,97						
Zuschlag	<b>Balkon</b>	OG2	<b>6,82</b>		6,82		25% vom NW/m <sup>2</sup>		0,25	2	46
Zubehör	<b>ER 2-26</b>	KG	<b>1,62</b>		1,62	0,30			0,30	1	1

<b>Whg-TOP 128</b>	<b>Mindestanteil:</b>	<b>47</b>	<b>von</b>	<b>14538</b>
--------------------	-----------------------	-----------	------------	--------------



<b>Whg-TOP 129</b>	<b>NFI.</b>		<b>72,77</b>		<b>72,77</b>	1,00		0,0%	1,00	73	
	VR	OG2	6,57	100%	6,57						
	WC	OG2	1,85	100%	1,85						
	Zimmer 2	OG2	13,27	100%	13,27						
	Gang	OG2	2,12	100%	2,12						
	AR	OG2	1,20	100%	1,20						
	Bad	OG2	4,40	100%	4,40						
	Zimmer 1	OG2	11,70	100%	11,70						
	Wohnen	OG2	23,45	100%	23,45						
	Kochen	OG2	8,21	100%	8,21						
Zuschlag	<b>Balkon</b>	OG2	<b>6,82</b>		6,82		25% vom NW/m <sup>2</sup>		0,25	2	75
Zubehör	<b>ER 2-27</b>	KG	<b>1,75</b>		1,75	0,30			0,30	1	1

<b>Whg-TOP 129</b>	<b>Mindestanteil:</b>	<b>76</b>	<b>von</b>	<b>14538</b>
--------------------	-----------------------	-----------	------------	--------------

<b>Whg-TOP 130</b>	<b>NFI.</b>		<b>84,76</b>		<b>81,77</b>	1,00		0,0%	1,00	82	
	VR	OG2	5,89	100%	5,89						
	WC	OG2	1,85	100%	1,85						
	Zimmer 2	OG2	13,47	100%	13,47						
	Gang	OG2	4,06	100%	4,06						
	AR	OG2	2,83	100%	2,83						
	Bad	OG2	7,00	100%	7,00						
	Zimmer 1	OG2	15,68	100%	15,68						
	Wohnen	OG2	19,85	100%	19,85						
	Kochen	OG2	8,15	100%	8,15						
	<b>Loggia</b>	OG2	<b>5,98</b>	50%	2,99						
Zuschlag	<b>Balkon</b>	OG2	<b>1,26</b>		1,26		25% vom NW/m <sup>2</sup>		0,25	1	83
Zubehör	<b>ER 2-28</b>	KG	<b>1,65</b>		1,65	0,30			0,30	1	1

<b>Whg-TOP 130</b>	<b>Mindestanteil:</b>	<b>84</b>	<b>von</b>	<b>14538</b>
--------------------	-----------------------	-----------	------------	--------------

<b>Whg-TOP 131</b>	<b>NFI.</b>		<b>49,11</b>		<b>46,30</b>	1,00	A19(-2%)	-2,0%	0,98	45	
	VR	OG2	4,34	100%	4,34						
	Bad/WC	OG2	6,00	100%	6,00						
	Zimmer	OG2	11,18	100%	11,18						
	Wohnen	OG2	16,86	100%	16,86						
	Kochen	OG2	5,10	100%	5,10						
	<b>Loggia</b>	OG2	<b>5,63</b>	50%	2,82					45	
Zubehör	<b>ER 2-29</b>	KG	<b>1,65</b>		1,65	0,30			0,30	1	1

<b>Whg-TOP 131</b>	<b>Mindestanteil:</b>	<b>46</b>	<b>von</b>	<b>14538</b>
--------------------	-----------------------	-----------	------------	--------------

<b>Whg-TOP 132</b>	<b>NFI.</b>		<b>48,12</b>		<b>45,80</b>	1,00	A19(-2%)	-2,0%	0,98	45	
	VR	OG2	4,34	100%	4,34						
	Bad/WC	OG2	6,00	100%	6,00						
	Zimmer	OG2	11,18	100%	11,18						
	Wohnen	OG2	16,86	100%	16,86						
	Kochen	OG2	5,10	100%	5,10						
	<b>Loggia</b>	OG2	<b>4,64</b>	50%	2,32						
Zuschlag	<b>Balkon</b>	OG2	<b>0,98</b>		0,98		25% vom NW/m <sup>2</sup>		0,25	1	46
Zubehör	<b>ER 2-30</b>	KG	<b>1,65</b>		1,65	0,30			0,30	1	1

<b>Whg-TOP 132</b>	<b>Mindestanteil:</b>	<b>47</b>	<b>von</b>	<b>14538</b>
--------------------	-----------------------	-----------	------------	--------------



<b>Whg-TOP 133</b>	<b>NFI.</b>		<b>49,11</b>		<b>46,30</b>	1,00	A19(-2%)	-2,0%	0,98	45
	VR	OG2	4,34	100%	4,34					
	Bad/WC	OG2	6,00	100%	6,00					
	Zimmer	OG2	11,18	100%	11,18					
	Wohnen	OG2	16,86	100%	16,86					
	Kochen	OG2	5,10	100%	5,10					
	<b>Loggia</b>	OG2	<b>5,63</b>	50%	2,82					45
Zubehör	<b>ER 2-31</b>	KG	<b>1,71</b>		1,71	0,30			0,30	1 1

<b>Whg-TOP 133</b>	<b>Mindestanteil:</b>	<b>46</b>	<b>von 14538</b>
--------------------	-----------------------	-----------	------------------

<b>Whg-TOP 134</b>	<b>NFI.</b>		<b>48,07</b>		<b>45,75</b>	1,00	A19(-2%)	-2,0%	0,98	45
	VR	OG2	4,34	100%	4,34					
	Bad/WC	OG2	5,95	100%	5,95					
	Zimmer	OG2	11,18	100%	11,18					
	Wohnen	OG2	16,86	100%	16,86					
	Kochen	OG2	5,10	100%	5,10					
	<b>Loggia</b>	OG2	<b>4,64</b>	50%	2,32					
Zuschlag	<b>Balkon</b>	OG2	<b>0,98</b>		0,98		25% vom NW/m <sup>2</sup>		0,25	1 46
Zubehör	<b>ER 2-32</b>	KG	<b>1,81</b>		1,81	0,30			0,30	1 1

<b>Whg-TOP 134</b>	<b>Mindestanteil:</b>	<b>47</b>	<b>von 14538</b>
--------------------	-----------------------	-----------	------------------

#### Obergeschoß 3

<b>Whg-TOP 135</b>	<b>NFI.</b>		<b>42,93</b>		<b>42,93</b>	1,00	A19(-2%)	-2,0%	0,98	42
	VR	OG3	4,40	100%	4,40					
	Bad/WC	OG3	5,16	100%	5,16					
	Zimmer	OG3	11,49	100%	11,49					
	Wohnen	OG3	16,33	100%	16,33					
	Kochen	OG3	5,55	100%	5,55					
Zuschlag	<b>Balkon</b>	OG3	<b>5,90</b>		5,90		25% vom NW/m <sup>2</sup>		0,25	1 43
Zubehör	<b>ER 2-33</b>	KG	<b>1,96</b>		1,96	0,30			0,30	1 1

<b>Whg-TOP 135</b>	<b>Mindestanteil:</b>	<b>44</b>	<b>von 14538</b>
--------------------	-----------------------	-----------	------------------

<b>Whg-TOP 136</b>	<b>NFI.</b>		<b>70,71</b>		<b>67,38</b>	1,00		0,0%	1,00	67
	VR	OG3	3,18	100%	3,18					
	Gang	OG3	2,58	100%	2,58					
	AR	OG3	1,67	100%	1,67					
	WC	OG3	1,85	100%	1,85					
	Bad	OG3	6,33	100%	6,33					
	Zimmer 1	OG3	10,50	100%	10,50					
	Zimmer 2	OG3	11,04	100%	11,04					
	Wohnen	OG3	20,90	100%	20,90					
	Kochen	OG3	6,00	100%	6,00					
	<b>Loggia</b>	OG3	<b>6,66</b>	50%	3,33					67
Zubehör	<b>ER 2-34</b>	KG	<b>1,97</b>		1,97	0,30			0,30	1 1

<b>Whg-TOP 136</b>	<b>Mindestanteil:</b>	<b>68</b>	<b>von 14538</b>
--------------------	-----------------------	-----------	------------------



<b>Whg-TOP 137</b>	<b>NFI.</b>		<b>42,52</b>		<b>39,48</b>	1,00	A19(-2%)	-2,0%	0,98	39	
	VR/Kochen	OG3	7,23	100%	7,23						
	Bad	OG3	6,10	100%	6,10						
	Wohnen	OG3	23,10	100%	23,10						
	<b>Loggia</b>	OG3	<b>6,09</b>	50%	3,05					39	
Zubehör	<b>ER 2-35</b>	KG	<b>2,01</b>		2,01	0,30			0,30	1	1

<b>Whg-TOP 137</b>	<b>Mindestanteil:</b>	<b>40</b>	<b>von</b>	<b>14538</b>
--------------------	-----------------------	-----------	------------	--------------

<b>Whg-TOP 138</b>	<b>NFI.</b>		<b>76,30</b>		<b>72,53</b>	1,00		0,0%	1,00	73	
	VR	OG3	7,94	100%	7,94						
	WC	OG3	1,85	100%	1,85						
	Gang	OG3	2,57	100%	2,57						
	Bad	OG3	4,73	100%	4,73						
	Zimmer 1	OG3	11,84	100%	11,84						
	Zimmer 2	OG3	11,04	100%	11,04						
	Wohnen	OG3	21,83	100%	21,83						
	Kochen	OG3	6,95	100%	6,95						
	<b>Loggia</b>	OG3	<b>7,55</b>	50%	3,78					73	
Zubehör	<b>ER 2-36</b>	KG	<b>1,81</b>		1,81	0,30			0,30	1	1

<b>Whg-TOP 138</b>	<b>Mindestanteil:</b>	<b>74</b>	<b>von</b>	<b>14538</b>
--------------------	-----------------------	-----------	------------	--------------

<b>Whg-TOP 139</b>			<b>51,99</b>		<b>49,50</b>	1,00	A19(-2%)	-2,0%	0,98	49	
	VR	OG3	4,85	100%	4,85						
	AR	OG3	1,54	100%	1,54						
	Bad/WC	OG3	5,87	100%	5,87						
	Zimmer	OG3	13,25	100%	13,25						
	Wohnen	OG3	17,74	100%	17,74						
	Kochen	OG3	3,76	100%	3,76						
	<b>Loggia</b>	OG3	<b>4,98</b>	50%	2,49						
Zuschlag	<b>Balkon</b>	OG3	<b>1,36</b>		1,36		25% vom NW/m <sup>2</sup>		0,25	1	50
Zubehör	<b>ER 4-3</b>	KG	<b>2,01</b>		2,01	0,30			0,30	1	1

<b>Whg-TOP 139</b>	<b>Mindestanteil:</b>	<b>51</b>	<b>von</b>	<b>14538</b>
--------------------	-----------------------	-----------	------------	--------------

<b>Whg-TOP 140</b>			<b>45,14</b>		<b>45,14</b>	1,00	A19(-2%)	-2,0%	0,98	44	
	Bad/WC	OG3	6,38	100%	6,38						
	Zimmer	OG3	11,72	100%	11,72						
	Wohnen	OG3	17,07	100%	17,07						
	Kochen	OG3	9,97	100%	9,97						
Zuschlag	<b>Balkon</b>	OG3	<b>6,82</b>		6,82		25% vom NW/m <sup>2</sup>		0,25	2	46
Zubehör	<b>ER 2-38</b>	KG	<b>1,81</b>		1,81	0,30			0,30	1	1

<b>Whg-TOP 140</b>	<b>Mindestanteil:</b>	<b>47</b>	<b>von</b>	<b>14538</b>
--------------------	-----------------------	-----------	------------	--------------





<b>Whg-TOP 141</b>			<b>45,14</b>		<b>45,14</b>	1,00	A19(-2%)	-2,0%	0,98	44	
	Bad/WC	OG3	6,38	100%	6,38						
	Zimmer	OG3	11,72	100%	11,72						
	Wohnen	OG3	17,07	100%	17,07						
	Kochen	OG3	9,97	100%	9,97						
Zuschlag	<b>Balkon</b>	OG3	<b>6,82</b>		6,82		25% vom NW/m <sup>2</sup>		0,25	2	46
Zubehör	<b>ER 2-39</b>	KG	<b>1,81</b>		1,81	0,30			0,30	1	1
<b>Whg-TOP 141</b>	<b>Mindestanteil:</b>		<b>47</b>	<b>von</b>	<b>14538</b>						

<b>Whg-TOP 142</b>			<b>45,14</b>		<b>45,14</b>	1,00	A19(-2%)	-2,0%	0,98	44	
	Bad/WC	OG3	6,38	100%	6,38						
	Zimmer	OG3	11,72	100%	11,72						
	Wohnen	OG3	17,07	100%	17,07						
	Kochen	OG3	9,97	100%	9,97						
Zuschlag	<b>Balkon</b>	OG3	<b>6,82</b>		6,82		25% vom NW/m <sup>2</sup>		0,25	2	46
Zubehör	<b>ER 2-40</b>	KG	<b>1,81</b>		1,81	0,30			0,30	1	1
<b>Whg-TOP 142</b>	<b>Mindestanteil:</b>		<b>47</b>	<b>von</b>	<b>14538</b>						

<b>Whg-TOP 143</b>			<b>45,14</b>		<b>45,14</b>	1,00	A19(-2%)	-2,0%	0,98	44	
	Bad/WC	OG3	6,38	100%	6,38						
	Zimmer	OG3	11,72	100%	11,72						
	Wohnen	OG3	17,07	100%	17,07						
	Kochen	OG3	9,97	100%	9,97						
Zuschlag	<b>Balkon</b>	OG3	<b>6,82</b>		6,82		25% vom NW/m <sup>2</sup>		0,25	2	46
Zubehör	<b>ER 2-41</b>	KG	<b>1,81</b>		1,81	0,30			0,30	1	1
<b>Whg-TOP 143</b>	<b>Mindestanteil:</b>		<b>47</b>	<b>von</b>	<b>14538</b>						

<b>Whg-TOP 144</b>	<b>NFI.</b>		<b>72,77</b>		<b>72,77</b>	1,00		0,0%	1,00	73	
	VR	OG3	6,57	100%	6,57						
	WC	OG3	1,85	100%	1,85						
	Zimmer 2	OG3	13,27	100%	13,27						
	Gang	OG3	2,12	100%	2,12						
	AR	OG3	1,20	100%	1,20						
	Bad	OG3	4,40	100%	4,40						
	Zimmer 1	OG3	11,70	100%	11,70						
	Wohnen	OG3	23,45	100%	23,45						
	Kochen	OG3	8,21	100%	8,21						
Zuschlag	<b>Balkon</b>	OG3	<b>6,82</b>		6,82		25% vom NW/m <sup>2</sup>		0,25	2	75
Zubehör	<b>ER 2-42</b>	KG	<b>1,81</b>		1,81	0,30			0,30	1	1
<b>Whg-TOP 144</b>	<b>Mindestanteil:</b>		<b>76</b>	<b>von</b>	<b>14538</b>						



<b>Whg-TOP 145</b>	<b>NFI.</b>		<b>86,02</b>		<b>82,40</b>	1,00		0,0%	1,00	82
	VR	OG3	5,89	100%	5,89					
	WC	OG3	1,85	100%	1,85					
	Zimmer 2	OG3	13,47	100%	13,47					
	Gang	OG3	4,06	100%	4,06					
	AR	OG3	2,83	100%	2,83					
	Bad	OG3	7,00	100%	7,00					
	Zimmer 1	OG3	15,68	100%	15,68					
	Wohnen	OG3	19,85	100%	19,85					
	Kochen	OG3	8,15	100%	8,15					
	<b>Loggia</b>	OG3	<b>7,24</b>	50%	3,62					82
Zubehör	<b>ER 2-43</b>	KG	<b>1,81</b>		1,81	0,30			0,30	1

<b>Whg-TOP 145</b>	<b>Mindestanteil:</b>	<b>83</b>	<b>von</b>	<b>14538</b>
--------------------	-----------------------	-----------	------------	--------------

<b>Whg-TOP 146</b>	<b>NFI.</b>		<b>48,12</b>		<b>45,80</b>	1,00	A19(-2%)	-2,0%	0,98	45
	VR	OG3	4,34	100%	4,34					
	Bad/WC	OG3	6,00	100%	6,00					
	Zimmer	OG3	11,18	100%	11,18					
	Wohnen	OG3	16,86	100%	16,86					
	Kochen	OG3	5,10	100%	5,10					
	<b>Loggia</b>	OG3	<b>4,64</b>	50%	2,32					
Zuschlag	<b>Balkon</b>	OG3	<b>0,99</b>		0,99		25% vom NW/m <sup>2</sup>		0,25	1
Zubehör	<b>ER 2-44</b>	KG	<b>1,95</b>		1,95	0,30			0,30	1

<b>Whg-TOP 146</b>	<b>Mindestanteil:</b>	<b>47</b>	<b>von</b>	<b>14538</b>
--------------------	-----------------------	-----------	------------	--------------

<b>Whg-TOP 147</b>	<b>NFI.</b>		<b>49,10</b>		<b>46,29</b>	1,00	A19(-2%)	-2,0%	0,98	45
	VR	OG3	4,34	100%	4,34					
	Bad/WC	OG3	6,00	100%	6,00					
	Zimmer	OG3	11,18	100%	11,18					
	Wohnen	OG3	16,86	100%	16,86					
	Kochen	OG3	5,10	100%	5,10					
	<b>Loggia</b>	OG3	<b>5,62</b>	50%	2,81					45
Zubehör	<b>ER 2-45</b>	KG	<b>1,94</b>		1,94	0,30			0,30	1

<b>Whg-TOP 147</b>	<b>Mindestanteil:</b>	<b>46</b>	<b>von</b>	<b>14538</b>
--------------------	-----------------------	-----------	------------	--------------

<b>Whg-TOP 148</b>	<b>NFI.</b>		<b>48,12</b>		<b>45,80</b>	1,00	A19(-2%)	-2,0%	0,98	45
	VR	OG3	4,34	100%	4,34					
	Bad/WC	OG3	6,00	100%	6,00					
	Zimmer	OG3	11,18	100%	11,18					
	Wohnen	OG3	16,86	100%	16,86					
	Kochen	OG3	5,10	100%	5,10					
	<b>Loggia</b>	OG3	<b>4,64</b>	50%	2,32					
Zuschlag	<b>Balkon</b>	OG3	<b>0,99</b>		0,99		25% vom NW/m <sup>2</sup>		0,25	1
Zubehör	<b>ER 2-46</b>	KG	<b>1,68</b>		1,68	0,30			0,30	1

<b>Whg-TOP 148</b>	<b>Mindestanteil:</b>	<b>47</b>	<b>von</b>	<b>14538</b>
--------------------	-----------------------	-----------	------------	--------------



<b>Whg-TOP 149</b>	<b>NFI.</b>		<b>49,05</b>		<b>46,24</b>	1,00	A19(-2%)	-2,0%	0,98	45	
	VR	OG3	4,34	100%	4,34						
	Bad/WC	OG3	5,95	100%	5,95						
	Zimmer	OG3	11,18	100%	11,18						
	Wohnen	OG3	16,86	100%	16,86						
	Kochen	OG3	5,10	100%	5,10						
	<b>Loggia</b>	OG3	<b>5,62</b>	50%	2,81					45	
Zubehör	<b>ER 2-47</b>	KG	<b>1,68</b>		1,68	0,30			0,30	1	1

<b>Whg-TOP 149</b>	<b>Mindestanteil:</b>	<b>46</b>	<b>von 14538</b>
--------------------	-----------------------	-----------	------------------

#### Obergeschoß 4

<b>Whg-TOP 150</b>	<b>NFI.</b>		<b>42,93</b>		<b>42,93</b>	1,00	A19(-2%)	-2,0%	0,98	42	
	VR	OG4	4,40	100%	4,40						
	Bad/WC	OG4	5,16	100%	5,16						
	Zimmer	OG4	11,49	100%	11,49						
	Wohnen	OG4	16,33	100%	16,33						
	Kochen	OG4	5,55	100%	5,55						
Zuschlag	<b>Balkon</b>	OG4	<b>5,90</b>		5,90		25% vom NW/m <sup>2</sup>		0,25	1	43
Zubehör	<b>ER 2-48</b>	KG	<b>1,68</b>		1,68	0,30			0,30	1	1

<b>Whg-TOP 150</b>	<b>Mindestanteil:</b>	<b>44</b>	<b>von 14538</b>
--------------------	-----------------------	-----------	------------------

<b>Whg-TOP 151</b>	<b>NFI.</b>		<b>70,81</b>		<b>67,43</b>	1,00		0,0%	1,00	67	
	VR	OG4	3,18	100%	3,18						
	Gang	OG4	2,58	100%	2,58						
	AR	OG4	1,67	100%	1,67						
	WC	OG4	1,85	100%	1,85						
	Bad	OG4	6,33	100%	6,33						
	Zimmer 1	OG4	10,50	100%	10,50						
	Zimmer 2	OG4	11,04	100%	11,04						
	Wohnen	OG4	20,90	100%	20,90						
	Kochen	OG4	6,00	100%	6,00						
	<b>Loggia</b>	OG4	<b>6,76</b>	50%	3,38					67	
Zubehör	<b>ER 2-49</b>	KG	<b>1,68</b>		1,68	0,30			0,30	1	1

<b>Whg-TOP 151</b>	<b>Mindestanteil:</b>	<b>68</b>	<b>von 14538</b>
--------------------	-----------------------	-----------	------------------

<b>Whg-TOP 152</b>	<b>NFI.</b>		<b>42,57</b>		<b>39,50</b>	1,00	A19(-2%)	-2,0%	0,98	39	
	VR/Kochen	OG4	7,23	100%	7,23						
	Bad	OG4	6,10	100%	6,10						
	Wohnen	OG4	23,10	100%	23,10						
	<b>Loggia</b>	OG4	<b>6,14</b>	50%	3,07					39	
Zubehör	<b>ER 2-50</b>	KG	<b>1,71</b>		1,71	0,30			0,30	1	1

<b>Whg-TOP 152</b>	<b>Mindestanteil:</b>	<b>40</b>	<b>von 14538</b>
--------------------	-----------------------	-----------	------------------



<b>Whg-TOP 153</b>	<b>NFI.</b>		<b>76,22</b>		<b>72,49</b>	1,00		0,0%	1,00	72	
	VR	OG4	7,94	100%	7,94						
	WC	OG4	1,85	100%	1,85						
	Gang	OG4	2,57	100%	2,57						
	Bad	OG4	4,73	100%	4,73						
	Zimmer 1	OG4	11,84	100%	11,84						
	Zimmer 2	OG4	11,04	100%	11,04						
	Wohnen	OG4	21,83	100%	21,83						
	Kochen	OG4	6,95	100%	6,95						
	<b>Loggia</b>	OG4	<b>7,47</b>	50%	3,74					72	
Zubehör	<b>ER 2-51</b>	KG	<b>1,96</b>		1,96	0,30			0,30	1	1

<b>Whg-TOP 153</b>	<b>Mindestanteil:</b>	<b>73</b>	<b>von</b>	<b>14538</b>
--------------------	-----------------------	-----------	------------	--------------

<b>Whg-TOP 154</b>			<b>51,99</b>		<b>49,50</b>	1,00	A19(-2%)	-2,0%	0,98	49	
	VR	OG4	4,85	100%	4,85						
	AR	OG4	1,54	100%	1,54						
	Bad/WC	OG4	5,87	100%	5,87						
	Zimmer	OG4	13,25	100%	13,25						
	Wohnen	OG4	17,74	100%	17,74						
	Kochen	OG4	3,76	100%	3,76						
	<b>Loggia</b>	OG4	<b>4,98</b>	50%	2,49						
Zuschlag	<b>Balkon</b>	OG4	<b>1,36</b>		1,36		25% vom NW/m <sup>2</sup>		0,25	1	50
Zubehör	<b>ER 4-4</b>	KG	<b>2,01</b>		2,01	0,30			0,30	1	1

<b>Whg-TOP 154</b>	<b>Mindestanteil:</b>	<b>51</b>	<b>von</b>	<b>14538</b>
--------------------	-----------------------	-----------	------------	--------------

<b>Whg-TOP 155</b>			<b>45,14</b>		<b>45,14</b>	1,00	A19(-2%)	-2,0%	0,98	44	
	Bad/WC	OG4	6,38	100%	6,38						
	Zimmer	OG4	11,72	100%	11,72						
	Wohnen	OG4	17,07	100%	17,07						
	Kochen	OG4	9,97	100%	9,97						
Zuschlag	<b>Balkon</b>	OG4	<b>6,82</b>		6,82		25% vom NW/m <sup>2</sup>		0,25	2	46
Zubehör	<b>ER 2-53</b>	KG	<b>1,94</b>		1,94	0,30			0,30	1	1

<b>Whg-TOP 155</b>	<b>Mindestanteil:</b>	<b>47</b>	<b>von</b>	<b>14538</b>
--------------------	-----------------------	-----------	------------	--------------

<b>Whg-TOP 156</b>			<b>45,14</b>		<b>45,14</b>	1,00	A19(-2%)	-2,0%	0,98	44	
	Bad/WC	OG4	6,38	100%	6,38						
	Zimmer	OG4	11,72	100%	11,72						
	Wohnen	OG4	17,07	100%	17,07						
	Kochen	OG4	9,97	100%	9,97						
Zuschlag	<b>Balkon</b>	OG4	<b>6,82</b>		6,82		25% vom NW/m <sup>2</sup>		0,25	2	46
Zubehör	<b>ER 2-54</b>	KG	<b>1,94</b>		1,94	0,30			0,30	1	1

<b>Whg-TOP 156</b>	<b>Mindestanteil:</b>	<b>47</b>	<b>von</b>	<b>14538</b>
--------------------	-----------------------	-----------	------------	--------------



<b>Whg-TOP 157</b>			<b>45,14</b>		<b>45,14</b>	1,00	A19(-2%)	-2,0%	0,98	44	
	Bad/WC	OG4	6,38	100%	6,38						
	Zimmer	OG4	11,72	100%	11,72						
	Wohnen	OG4	17,07	100%	17,07						
	Kochen	OG4	9,97	100%	9,97						
Zuschlag	<b>Balkon</b>	OG4	<b>6,82</b>		6,82		25% vom NW/m <sup>2</sup>		0,25	2	46
Zubehör	<b>ER 2-55</b>	KG	<b>1,94</b>		1,94	0,30			0,30	1	1
<b>Whg-TOP 157</b>	<b>Mindestanteil:</b>		<b>47</b>	<b>von</b>	<b>14538</b>						

<b>Whg-TOP 158</b>			<b>45,14</b>		<b>45,14</b>	1,00	A19(-2%)	-2,0%	0,98	44	
	Bad/WC	OG4	6,38	100%	6,38						
	Zimmer	OG4	11,72	100%	11,72						
	Wohnen	OG4	17,07	100%	17,07						
	Kochen	OG4	9,97	100%	9,97						
Zuschlag	<b>Balkon</b>	OG4	<b>6,82</b>		6,82		25% vom NW/m <sup>2</sup>		0,25	2	46
Zubehör	<b>ER 2-56</b>	KG	<b>1,96</b>		1,96	0,30			0,30	1	1
<b>Whg-TOP 158</b>	<b>Mindestanteil:</b>		<b>47</b>	<b>von</b>	<b>14538</b>						

<b>Whg-TOP 159</b>	<b>NFI.</b>		<b>72,77</b>		<b>72,77</b>	1,00		0,0%	1,00	73	
	VR	OG4	6,57	100%	6,57						
	WC	OG4	1,85	100%	1,85						
	Zimmer 2	OG4	13,27	100%	13,27						
	Gang	OG4	2,12	100%	2,12						
	AR	OG4	1,20	100%	1,20						
	Bad	OG4	4,40	100%	4,40						
	Zimmer 1	OG4	11,70	100%	11,70						
	Wohnen	OG4	23,45	100%	23,45						
	Kochen	OG4	8,21	100%	8,21						
Zuschlag	<b>Balkon</b>	OG4	<b>6,82</b>		6,82		25% vom NW/m <sup>2</sup>		0,25	2	75
Zubehör	<b>ER 2-57</b>	KG	<b>1,65</b>		1,65	0,30			0,30	1	1
<b>Whg-TOP 159</b>	<b>Mindestanteil:</b>		<b>76</b>	<b>von</b>	<b>14538</b>						

<b>Whg-TOP 160</b>	<b>NFI.</b>		<b>84,76</b>		<b>81,77</b>	1,00	Z1(+10%), A10(-5%)	5,0%	1,05	86	
	VR	OG4	5,89	100%	5,89						
	WC	OG4	1,85	100%	1,85						
	Zimmer 2	OG4	13,47	100%	13,47						
	Gang	OG4	4,06	100%	4,06						
	AR	OG4	2,83	100%	2,83						
	Bad	OG4	7,00	100%	7,00						
	Zimmer 1	OG4	15,68	100%	15,68						
	Wohnen	OG4	19,85	100%	19,85						
	Kochen	OG4	8,15	100%	8,15						
	<b>Loggia</b>	OG4	<b>5,98</b>	50%	2,99						
Zuschlag	<b>Balkon</b>	OG4	<b>1,26</b>		1,26		25% vom NW/m <sup>2</sup>		0,26	1	87
Zubehör	<b>ER 2-58</b>	KG	<b>1,68</b>		1,68	0,30			0,30	1	1
<b>Whg-TOP 160</b>	<b>Mindestanteil:</b>		<b>88</b>	<b>von</b>	<b>14538</b>						



<b>Whg-TOP 161</b>	<b>NFI.</b>		<b>49,11</b>		<b>46,30</b>	1,00	Z1(+10%), A10(-5%), A19(-2%)	3,0%	1,03	48
	VR	OG4	4,34	100%	4,34					
	Bad/WC	OG4	6,00	100%	6,00					
	Zimmer	OG4	11,18	100%	11,18					
	Wohnen	OG4	16,86	100%	16,86					
	Kochen	OG4	5,10	100%	5,10					
	<b>Loggia</b>	OG4	<b>5,63</b>	50%	2,82					48
Zubehör	<b>ER 2-59</b>	KG	<b>1,68</b>		1,68	0,30			0,30	1

<b>Whg-TOP 161</b>	<b>Mindestanteil:</b>	<b>49</b>	<b>von</b>	<b>14538</b>
--------------------	-----------------------	-----------	------------	--------------

<b>Whg-TOP 162</b>	<b>NFI.</b>		<b>48,12</b>		<b>45,80</b>	1,00	Z1(+10%), A10(-5%), A19(-2%)	3,0%	1,03	47
	VR	OG4	4,34	100%	4,34					
	Bad/WC	OG4	6,00	100%	6,00					
	Zimmer	OG4	11,18	100%	11,18					
	Wohnen	OG4	16,86	100%	16,86					
	Kochen	OG4	5,10	100%	5,10					
	<b>Loggia</b>	OG4	<b>4,64</b>	50%	2,32					
Zuschlag	<b>Balkon</b>	OG4	<b>0,98</b>		0,98		25% vom NW/m <sup>2</sup>		0,26	1
Zubehör	<b>ER 2-60</b>	KG	<b>1,68</b>		1,68	0,30			0,30	1

<b>Whg-TOP 162</b>	<b>Mindestanteil:</b>	<b>49</b>	<b>von</b>	<b>14538</b>
--------------------	-----------------------	-----------	------------	--------------

<b>Whg-TOP 163</b>	<b>NFI.</b>		<b>49,11</b>		<b>46,30</b>	1,00	Z1(+10%), A10(-5%), A19(-2%)	3,0%	1,03	48
	VR	OG4	4,34	100%	4,34					
	Bad/WC	OG4	6,00	100%	6,00					
	Zimmer	OG4	11,18	100%	11,18					
	Wohnen	OG4	16,86	100%	16,86					
	Kochen	OG4	5,10	100%	5,10					
	<b>Loggia</b>	OG4	<b>5,63</b>	50%	2,82					48
Zubehör	<b>ER 2-61</b>	KG	<b>1,68</b>		1,68	0,30			0,30	1

<b>Whg-TOP 163</b>	<b>Mindestanteil:</b>	<b>49</b>	<b>von</b>	<b>14538</b>
--------------------	-----------------------	-----------	------------	--------------

<b>Whg-TOP 164</b>	<b>NFI.</b>		<b>48,07</b>		<b>45,75</b>	1,00	Z1(+10%), A10(-5%), A19(-2%)	3,0%	1,03	47
	VR	OG4	4,34	100%	4,34					
	Bad/WC	OG4	5,95	100%	5,95					
	Zimmer	OG4	11,18	100%	11,18					
	Wohnen	OG4	16,86	100%	16,86					
	Kochen	OG4	5,10	100%	5,10					
	<b>Loggia</b>	OG4	<b>4,64</b>	50%	2,32					
Zuschlag	<b>Balkon</b>	OG4	<b>0,98</b>		0,98		25% vom NW/m <sup>2</sup>		0,26	1
Zubehör	<b>ER 2-62</b>	KG	<b>1,94</b>		1,94	0,30			0,30	1

<b>Whg-TOP 164</b>	<b>Mindestanteil:</b>	<b>49</b>	<b>von</b>	<b>14538</b>
--------------------	-----------------------	-----------	------------	--------------



**Obergeschoß 5**

<b>Whg-TOP 165</b>	<b>NFI.</b>		<b>42,93</b>		<b>42,93</b>	1,00	A19(-2%)	-2,0%	0,98	42	
	VR	OG5	4,40	100%	4,40						
	Bad/WC	OG5	5,16	100%	5,16						
	Zimmer	OG5	11,49	100%	11,49						
	Wohnen	OG5	16,33	100%	16,33						
	Kochen	OG5	5,55	100%	5,55						
Zuschlag	<b>Terrasse 1</b>	OG5	<b>10,65</b>		10,65		25% vom NW/m <sup>2</sup>		0,25	3	45
<b>Zubehör</b>	<b>Terrasse 2 Top 165</b>	OG5	11,84		11,84	0,15			0,15	2	
Zubehör	<b>ER 2-63</b>	KG	<b>1,95</b>		1,95	0,30			0,30	1	3

<b>Whg-TOP 165</b>	<b>Mindestanteil:</b>	<b>48</b>	<b>von</b>	<b>14538</b>
--------------------	-----------------------	-----------	------------	--------------

<b>Whg-TOP 166</b>	<b>NFI.</b>		<b>71,06</b>		<b>67,73</b>	1,00		0,0%	1,00	68	
	VR	OG5	3,18	100%	3,18						
	Gang	OG5	5,07	100%	5,07						
	AR	OG5	1,67	100%	1,67						
	WC	OG5	1,85	100%	1,85						
	Bad	OG5	4,19	100%	4,19						
	Zimmer 2	OG5	10,50	100%	10,50						
	Zimmer 1	OG5	11,04	100%	11,04						
	Wohnen	OG5	20,90	100%	20,90						
	Kochen	OG5	6,00	100%	6,00						
	<b>Loggia</b>	OG5	<b>6,66</b>	50%	3,33						
Zuschlag	<b>Terrasse 1</b>	OG5	<b>22,74</b>		22,74		25% vom NW/m <sup>2</sup>		0,25	6	74
<b>Zubehör</b>	<b>Terrasse 2 Top 166</b>	OG5	25,05		25,05	0,15			0,15	4	
Zubehör	<b>ER 2-72</b>	KG	<b>2,19</b>		2,19	0,30			0,30	1	5

<b>Whg-TOP 166</b>	<b>Mindestanteil:</b>	<b>79</b>	<b>von</b>	<b>14538</b>
--------------------	-----------------------	-----------	------------	--------------

<b>Whg-TOP 167</b>	<b>NFI.</b>		<b>42,57</b>		<b>39,50</b>	1,00	A19(-2%)	-2,0%	0,98	39	
	VR/Kochen	OG5	7,23	100%	7,23						
	Bad	OG5	6,10	100%	6,10						
	Wohnen	OG5	23,10	100%	23,10						
	<b>Loggia</b>	OG5	<b>6,14</b>	50%	3,07						39
Zubehör	<b>ER 2-65</b>	KG	<b>2,26</b>		2,26	0,30			0,30	1	1

<b>Whg-TOP 167</b>	<b>Mindestanteil:</b>	<b>40</b>	<b>von</b>	<b>14538</b>
--------------------	-----------------------	-----------	------------	--------------

<b>Whg-TOP 168</b>	<b>NFI.</b>		<b>76,26</b>		<b>72,49</b>	1,00		0,0%	1,00	72	
	VR	OG5	7,90	100%	7,90						
	WC	OG5	1,85	100%	1,85						
	Gang	OG5	2,57	100%	2,57						
	Bad	OG5	4,73	100%	4,73						
	Zimmer 1	OG5	11,84	100%	11,84						
	Zimmer 2	OG5	11,04	100%	11,04						
	Wohnen	OG5	21,83	100%	21,83						
	Kochen	OG5	6,95	100%	6,95						
	<b>Loggia</b>	OG5	<b>7,55</b>	50%	3,78						72
Zubehör	<b>ER 2-68</b>	KG	<b>3,65</b>		3,65	0,30			0,30	1	1

<b>Whg-TOP 168</b>	<b>Mindestanteil:</b>	<b>73</b>	<b>von</b>	<b>14538</b>
--------------------	-----------------------	-----------	------------	--------------



<b>Whg-TOP 169</b>			<b>51,99</b>		<b>49,50</b>	1,00	A19(-2%)	-2,0%	0,98	49	
	VR	OG5	4,85	100%	4,85						
	AR	OG5	1,54	100%	1,54						
	Bad/WC	OG5	5,87	100%	5,87						
	Zimmer	OG5	13,25	100%	13,25						
	Wohnen	OG5	17,74	100%	17,74						
	Kochen	OG5	3,76	100%	3,76						
	<b>Loggia</b>	OG5	<b>4,98</b>	50%	2,49						
Zuschlag	<b>Balkon</b>	OG5	<b>1,36</b>		1,36		25% vom NW/m <sup>2</sup>		0,25	1	50
Zubehör	<b>ER 2-67</b>	KG	<b>2,02</b>		2,02	0,30			0,30	1	1

<b>Whg-TOP 169</b>	<b>Mindestanteil:</b>	<b>51</b>	<b>von</b>	<b>14538</b>
--------------------	-----------------------	-----------	------------	--------------

<b>Whg-TOP 170</b>			<b>45,14</b>		<b>45,14</b>	1,00	Z1(+10%), A10(-5%), A19(-2%)	3,0%	1,03	46	
	Bad/WC	OG5	6,38	100%	6,38						
	Zimmer	OG5	11,72	100%	11,72						
	Wohnen	OG5	17,07	100%	17,07						
	Kochen	OG5	9,97	100%	9,97						
Zuschlag	<b>Balkon</b>	OG5	<b>6,82</b>		6,82		25% vom NW/m <sup>2</sup>		0,26	2	48
<b>Zubehör Terrasse Top 170</b>	Terrasse 1 Top 170	OG5	13,10		13,10	0,25			0,25	3	
	Terrasse 2 Top 170	OG5	37,02		37,02	0,15			0,15	6	
Zubehör	<b>ER 2-66</b>	KG	<b>2,29</b>		2,29	0,30			0,30	1	10

<b>Whg-TOP 170</b>	<b>Mindestanteil:</b>	<b>58</b>	<b>von</b>	<b>14538</b>
--------------------	-----------------------	-----------	------------	--------------

<b>Whg-TOP 171</b>			<b>45,14</b>		<b>45,14</b>	1,00	Z1(+10%), A10(-5%), A19(-2%)	3,0%	1,03	46	
	Bad/WC	OG5	6,38	100%	6,38						
	Zimmer	OG5	11,72	100%	11,72						
	Wohnen	OG5	17,07	100%	17,07						
	Kochen	OG5	9,97	100%	9,97						
Zuschlag	<b>Balkon</b>	OG5	<b>6,82</b>		6,82		25% vom NW/m <sup>2</sup>		0,26	2	48
<b>Zubehör Terrasse Top 171</b>	Terrasse 1 Top 171	OG5	13,20		13,20	0,25			0,25	3	
	Terrasse 2 Top 171	OG5	37,28		37,28	0,15			0,15	6	
Zubehör	<b>ER 2-37</b>	KG	<b>1,81</b>		1,81	0,30			0,30	1	10

<b>Whg-TOP 171</b>	<b>Mindestanteil:</b>	<b>58</b>	<b>von</b>	<b>14538</b>
--------------------	-----------------------	-----------	------------	--------------

<b>Whg-TOP 172</b>			<b>45,14</b>		<b>45,14</b>	1,00	Z1(+10%), A10(-5%), A19(-2%)	3,0%	1,03	46	
	Bad/WC	OG5	6,38	100%	6,38						
	Zimmer	OG5	11,72	100%	11,72						
	Wohnen	OG5	17,07	100%	17,07						
	Kochen	OG5	9,97	100%	9,97						
Zuschlag	<b>Balkon</b>	OG5	<b>6,82</b>		6,82		25% vom NW/m <sup>2</sup>		0,26	2	48
<b>Zubehör Terrasse Top 172</b>	Terrasse 1 Top 172	OG5	13,20		13,20	0,25			0,25	3	
	Terrasse 2 Top 172	OG5	37,29		37,29	0,15			0,15	6	
Zubehör	<b>ER 2-70</b>	KG	<b>2,19</b>		2,19	0,30			0,30	1	10

<b>Whg-TOP 172</b>	<b>Mindestanteil:</b>	<b>58</b>	<b>von</b>	<b>14538</b>
--------------------	-----------------------	-----------	------------	--------------





<b>Whg-TOP 173</b>			<b>45,03</b>		<b>45,03</b>	1,00	Z1(+10%), A10(-5%), A19(-2%)	5,0%	1,05	47	
	Bad/WC	OG5	6,38	100%	6,38						
	Zimmer	OG5	11,61	100%	11,61						
	Wohnen	OG5	17,07	100%	17,07						
	Kochen	OG5	9,97	100%	9,97						
Zuschlag	<b>Balkon</b>	OG5	<b>6,82</b>		6,82		25% vom NW/m <sup>2</sup>		0,26	2	49
<b>Zubehör Terrasse Top 173</b>	Terrasse 1 Top 173	OG5	13,17		13,17	0,25			0,25	3	
	Terrasse 2 Top 173	OG5	37,25		37,25	0,15			0,15	6	
Zubehör	<b>ER 2-71</b>	KG	<b>2,19</b>		2,19	0,30			0,30	1	10

<b>Whg-TOP 173</b>	<b>Mindestanteil:</b>	<b>59</b>	<b>von</b>	<b>14538</b>
--------------------	-----------------------	-----------	------------	--------------

<b>Whg-TOP 174</b>	<b>NFI.</b>		<b>94,11</b>		<b>94,11</b>	1,00	Z1(+10%), A10(-5%), Z6(+3%)	8,0%	1,08	102	
	VR	OG5	13,04	100%	13,04						
	WC	OG5	2,22	100%	2,22						
	Bad	OG5	6,33	100%	6,33						
	Zimmer 2	OG5	11,73	100%	11,73						
	Gang	OG5	1,79	100%	1,79						
	Dusche	OG5	3,33	100%	3,33						
	Zimmer 1	OG5	13,76	100%	13,76						
	Zimmer 3	OG5	11,79	100%	11,79						
	Wohnküche	OG5	30,12	100%	30,12						
Zuschlag	<b>Balkon</b>	OG5	<b>6,82</b>		6,82		25% vom NW/m <sup>2</sup>		0,27	2	
Zuschlag	<b>Terrasse 1</b>	OG5	<b>19,55</b>		19,55		25% vom NW/m <sup>2</sup>		0,27	5	109
Zubehör	<b>Terrasse 2 Top 174</b>	OG5	55,23		55,23	0,15			0,15	8	
Zubehör	<b>ER 2-64</b>	KG	<b>4,59</b>		4,59	0,30			0,30	1	9

<b>Whg-TOP 174</b>	<b>Mindestanteil:</b>	<b>118</b>	<b>von</b>	<b>14538</b>
--------------------	-----------------------	------------	------------	--------------

#### Obergeschoß 6

<b>Whg-TOP 175</b>	<b>NFI.</b>		<b>42,93</b>		<b>42,93</b>	1,00	Z1(+10%), A10(-5%), A19(-2%)	3,0%	1,03	44	
	VR	OG6	4,40	100%	4,40						
	Bad/WC	OG6	5,16	100%	5,16						
	Zimmer	OG6	11,49	100%	11,49						
	Wohnen	OG6	16,33	100%	16,33						
	Kochen	OG6	5,55	100%	5,55						
Zuschlag	<b>Balkon</b>	OG6	<b>5,06</b>		5,06		25% vom NW/m <sup>2</sup>		0,26	1	45
Zubehör	<b>ER 2-7</b>	KG	<b>2,29</b>		2,29	0,30			0,30	1	1

<b>Whg-TOP 175</b>	<b>Mindestanteil:</b>	<b>46</b>	<b>von</b>	<b>14538</b>
--------------------	-----------------------	-----------	------------	--------------



Whg-TOP 176	NFI.		83,33		83,33	1,00	Z1(+10%), A10(-5%), A19(-2%), Z6(+3%)	6,0%	1,06	88	
	VR	OG6	3,31	100%	3,31						
	Gang	OG6	5,07	100%	5,07						
	AR	OG6	1,67	100%	1,67						
	Bad	OG6	6,60	100%	6,60						
	Zimmer 1	OG6	11,04	100%	11,04						
	Zimmer 2	OG6	10,50	100%	10,50						
	Dusche/WC	OG6	5,84	100%	5,84						
	Zimmer 3	OG6	11,98	100%	11,98						
	Wohnen	OG6	21,24	100%	21,24						
	Kochen	OG6	6,08	100%	6,08						
Zuschlag	<b>Balkon</b>	OG6	<b>8,99</b>		8,99		25% vom NW/m <sup>2</sup>		0,27	2	
Zuschlag	<b>Balkon</b>	OG6	<b>11,93</b>		11,93		25% vom NW/m <sup>2</sup>		0,27	3	93
Zubehör	<b>ER 2-22</b>	KG	<b>1,62</b>		1,62	0,30			0,30	1	1

<b>Whg-TOP 176</b>	<b>Mindestanteil:</b>	<b>94 von 14538</b>
--------------------	-----------------------	---------------------

Whg-TOP 177	NFI.		86,70		86,70	1,00	Z1(+10%), A10(-5%), A19(-2%), Z6(+3%)	6,0%	1,06	92	
	VR	OG6	5,37	100%	5,37						
	Dusche/WC	OG6	5,99	100%	5,99						
	Zimmer 3	OG6	11,23	100%	11,23						
	Gang	OG6	2,68	100%	2,68						
	Bad	OG6	4,73	100%	4,73						
	Zimmer 1	OG6	11,84	100%	11,84						
	Zimmer 2	OG6	11,04	100%	11,04						
	Wohnen	OG6	23,19	100%	23,19						
	Kochen	OG6	10,63	100%	10,63						
Zuschlag	<b>Balkon</b>	OG6	<b>11,44</b>		11,44		25% vom NW/m <sup>2</sup>		0,27	3	95
Zubehör	<b>ER 2-69</b>	KG	<b>3,63</b>		3,63	0,30			0,30	1	1

<b>Whg-TOP 177</b>	<b>Mindestanteil:</b>	<b>96 von 14538</b>
--------------------	-----------------------	---------------------

Whg-TOP 178	NFI.		53,21		53,21	1,00	Z1(+10%), A10(-5%), A19(-2%)	3,0%	1,03	55	
	VR	OG6	5,66	100%	5,66						
	Dusche/WC	OG6	6,08	100%	6,08						
	AR	OG6	1,80	100%	1,80						
	Zimmer	OG6	13,43	100%	13,43						
	Wohnen	OG6	19,35	100%	19,35						
	Kochen	OG6	6,89	100%	6,89						
Zuschlag	<b>Balkon</b>	OG6	<b>1,38</b>		1,38		25% vom NW/m <sup>2</sup>		0,26	1	
Zuschlag	<b>Terrasse</b>	OG6	<b>21,47</b>		21,47		25% vom NW/m <sup>2</sup>		0,26	6	62
Zubehör	<b>ER 2-52</b>	KG	<b>1,94</b>		1,94	0,30			0,30	1	1

<b>Whg-TOP 178</b>	<b>Mindestanteil:</b>	<b>63 von 14538</b>
--------------------	-----------------------	---------------------



## STIEGE 2

### Erdgeschoss

<b>Geschäft-TOP G-2</b>	<b>NFI.</b>		<b>153,24</b>		<b>153,24</b>	1,00	Z16(20%)	20,0%	1,20	184	
	Geschäft	EG	140,84	100%	140,84						
	WC	EG	2,32	100%	2,32						
	AR	EG	1,17	100%	1,17						
	Umkleide	EG	8,91	100%	8,91						
Zuschlag	<b>Terrasse</b>	EG	<b>20,74</b>		20,74		25% vom NW/m <sup>2</sup>		0,30	6	190

<b>Geschäft-TOP G-2</b>	<b>Mindestanteil:</b>	<b>190</b>	<b>von</b>	<b>14538</b>
-------------------------	-----------------------	------------	------------	--------------

### Obergeschoß 1

<b>Whg-TOP 201</b>			<b>31,80</b>		<b>31,80</b>	1,00	A9(-5%), A19(-2%)	-7,0%	0,93	30	
	VR/Kochen	OG1	6,99	100%	6,99						
	Bad	OG1	5,75	100%	5,75						
	Wohnen	OG1	19,06	100%	19,06						
Zuschlag	<b>Balkon</b>	OG1	<b>10,47</b>		10,47		25% vom NW/m <sup>2</sup>		0,23	2	32
Zubehör	<b>ER 3-1</b>	KG	<b>1,93</b>		1,93	0,30			0,30	1	1

<b>Whg-TOP 201</b>	<b>Mindestanteil:</b>	<b>33</b>	<b>von</b>	<b>14538</b>
--------------------	-----------------------	-----------	------------	--------------

<b>Whg-TOP 202</b>	<b>NFI.</b>		<b>42,12</b>		<b>37,35</b>	1,00	A19(-2%)	-2,0%	0,98	37	
	VR/Kochen	OG1	7,45	100%	7,45						
	Bad	OG1	6,21	100%	6,21						
	Wohnen	OG1	18,92	100%	18,92						
	<b>Loggia</b>	OG1	<b>9,54</b>	50%	4,77					37	
Zubehör	<b>ER 3-2</b>	KG	<b>1,92</b>		1,92	0,30			0,30	1	1

<b>Whg-TOP 202</b>	<b>Mindestanteil:</b>	<b>38</b>	<b>von</b>	<b>14538</b>
--------------------	-----------------------	-----------	------------	--------------

<b>Whg-TOP 203</b>	<b>NFI.</b>		<b>41,80</b>		<b>37,03</b>	1,00	A19(-2%)	-2,0%	0,98	36	
	VR/Kochen	OG1	7,31	100%	7,31						
	Bad	OG1	6,21	100%	6,21						
	Wohnen	OG1	18,74	100%	18,74						
	<b>Loggia</b>	OG1	<b>9,54</b>	50%	4,77					36	
Zubehör	<b>ER 3-3</b>	KG	<b>1,92</b>		1,92	0,30			0,30	1	1

<b>Whg-TOP 203</b>	<b>Mindestanteil:</b>	<b>37</b>	<b>von</b>	<b>14538</b>
--------------------	-----------------------	-----------	------------	--------------

<b>Whg-TOP 204</b>	<b>NFI.</b>		<b>40,84</b>		<b>36,61</b>	1,00	A19(-2%)	-2,0%	0,98	36	
	VR/Kochen	OG1	7,51	100%	7,51						
	Bad	OG1	6,13	100%	6,13						
	Wohnen	OG1	18,74	100%	18,74						
	<b>Loggia</b>	OG1	<b>8,46</b>	50%	4,23					36	
Zubehör	<b>ER 3-4</b>	KG	<b>1,92</b>		1,92	0,30			0,30	1	1

<b>Whg-TOP 204</b>	<b>Mindestanteil:</b>	<b>37</b>	<b>von</b>	<b>14538</b>
--------------------	-----------------------	-----------	------------	--------------



<b>Whg-TOP 205</b>	<b>NFI.</b>		<b>74,36</b>		<b>70,88</b>	1,00	A8(-3%)	-3,0%	0,97	69
	VR	OG1	2,15	100%	2,15					
	Wohn/Ess/Küche	OG1	29,01	100%	29,01					
	Gang	OG1	4,68	100%	4,68					
	WC	OG1	1,85	100%	1,85					
	Zimmer	OG1	12,50	100%	12,50					
	Bad	OG1	5,19	100%	5,19					
	Zimmer	OG1	12,02	100%	12,02					
	<b>Loggia</b>	OG1	<b>6,96</b>	50%	3,48					69
Zubehör	<b>ER 3-5</b>	KG	<b>1,93</b>		1,93	0,30			0,30	1

<b>Whg-TOP 205</b>	<b>Mindestanteil:</b>	<b>70 von 14538</b>
--------------------	-----------------------	---------------------

<b>Whg-TOP 206</b>	<b>NFI.</b>		<b>49,70</b>		<b>47,17</b>	1,00	A9(-5%), A19(-2%)	-7,0%	0,93	44
	VR	OG1	4,43	100%	4,43					
	Wohnen	OG1	17,21	100%	17,21					
	Kochen	OG1	5,04	100%	5,04					
	Bad	OG1	6,11	100%	6,11					
	Zimmer	OG1	11,85	100%	11,85					
	<b>Loggia</b>	OG1	<b>5,06</b>	50%	2,53					
Zuschlag	<b>Balkon</b>	OG1	<b>2,37</b>		2,37		25% vom NW/m <sup>2</sup>		0,23	1
Zubehör	<b>ER 3-6</b>	KG	<b>1,92</b>		1,92	0,30			0,30	1

<b>Whg-TOP 206</b>	<b>Mindestanteil:</b>	<b>46 von 14538</b>
--------------------	-----------------------	---------------------

<b>Whg-TOP 207</b>	<b>NFI.</b>		<b>75,25</b>		<b>72,52</b>	1,00		0,0%	1,00	73
	VR	OG1	4,00	100%	4,00					
	Wohn/Ess/Küche	OG1	30,74	100%	30,74					
	Zimmer 1	OG1	11,07	100%	11,07					
	Gang	OG1	3,10	100%	3,10					
	WC	OG1	1,85	100%	1,85					
	Bad	OG1	5,81	100%	5,81					
	AR	OG1	1,44	100%	1,44					
	Zimmer 2	OG1	11,78	100%	11,78					
	<b>Loggia</b>	OG1	<b>5,46</b>	50%	2,73					
Zuschlag	<b>Balkon</b>	OG1	<b>2,56</b>		2,56		25% vom NW/m <sup>2</sup>		0,25	1
Zubehör	<b>ER 3-7</b>	KG	<b>1,92</b>		1,92	0,30			0,30	1

<b>Whg-TOP 207</b>	<b>Mindestanteil:</b>	<b>75 von 14538</b>
--------------------	-----------------------	---------------------

**Obergeschoß 2**

<b>Whg-TOP 208</b>			<b>32,05</b>		<b>32,05</b>	1,00	A19(-2%)	-2,0%	0,98	31
	VR/Kochen	OG2	6,99	100%	6,99					
	Bad	OG2	5,75	100%	5,75					
	Wohnen	OG2	19,31	100%	19,31					
Zuschlag	<b>Balkon</b>	OG2	<b>10,47</b>		10,47		25% vom NW/m <sup>2</sup>		0,25	3
Zubehör	<b>ER 3-8</b>	KG	<b>1,92</b>		1,92	0,30			0,30	1

<b>Whg-TOP 208</b>	<b>Mindestanteil:</b>	<b>35 von 14538</b>
--------------------	-----------------------	---------------------



<b>Whg-TOP 209</b>	<b>NFI.</b>		<b>42,38</b>		<b>37,61</b>	1,00	A19(-2%)	-2,0%	0,98	37	
	VR/Kochen	OG2	7,45	100%	7,45						
	Bad	OG2	6,21	100%	6,21						
	Wohnen	OG2	19,18	100%	19,18						
	<b>Loggia</b>	OG2	<b>9,54</b>	50%	4,77					37	
Zubehör	<b>ER 3-9</b>	KG	<b>1,32</b>		1,32	0,30			0,30	1	1

<b>Whg-TOP 209</b>	<b>Mindestanteil:</b>	<b>38</b>	<b>von</b>	<b>14538</b>
--------------------	-----------------------	-----------	------------	--------------

<b>Whg-TOP 210</b>	<b>NFI.</b>		<b>42,38</b>		<b>37,61</b>	1,00	A19(-2%)	-2,0%	0,98	37	
	VR/Kochen	OG2	7,45	100%	7,45						
	Bad	OG2	6,21	100%	6,21						
	Wohnen	OG2	19,18	100%	19,18						
	<b>Loggia</b>	OG2	<b>9,54</b>	50%	4,77					37	
Zubehör	<b>ER 3-10</b>	KG	<b>1,32</b>		1,32	0,30			0,30	1	1

<b>Whg-TOP 210</b>	<b>Mindestanteil:</b>	<b>38</b>	<b>von</b>	<b>14538</b>
--------------------	-----------------------	-----------	------------	--------------

<b>Whg-TOP 211</b>	<b>NFI.</b>		<b>41,27</b>		<b>37,04</b>	1,00	A19(-2%)	-2,0%	0,98	36	
	VR/Kochen	OG2	7,45	100%	7,45						
	Bad	OG2	6,18	100%	6,18						
	Wohnen	OG2	19,18	100%	19,18						
	<b>Loggia</b>	OG2	<b>8,46</b>	50%	4,23					36	
Zubehör	<b>ER 3-11</b>	KG	<b>1,32</b>		1,32	0,30			0,30	1	1

<b>Whg-TOP 211</b>	<b>Mindestanteil:</b>	<b>37</b>	<b>von</b>	<b>14538</b>
--------------------	-----------------------	-----------	------------	--------------

<b>Whg-TOP 212</b>	<b>NFI.</b>		<b>75,60</b>		<b>72,12</b>	1,00		0,0%	1,00	72	
	VR	OG2	2,22	100%	2,22						
	Wohn/Ess/Küche	OG2	29,61	100%	29,61						
	Gang	OG2	4,68	100%	4,68						
	WC	OG2	1,85	100%	1,85						
	Zimmer	OG2	12,64	100%	12,64						
	Bad	OG2	5,29	100%	5,29						
	Zimmer	OG2	12,35	100%	12,35						
	<b>Loggia</b>	OG2	<b>6,96</b>	50%	3,48					72	
Zubehör	<b>ER 3-12</b>	KG	<b>1,32</b>		1,32	0,30			0,30	1	1

<b>Whg-TOP 212</b>	<b>Mindestanteil:</b>	<b>73</b>	<b>von</b>	<b>14538</b>
--------------------	-----------------------	-----------	------------	--------------

<b>Whg-TOP 213</b>	<b>NFI.</b>		<b>49,70</b>		<b>47,17</b>	1,00	A19(-2%)	-2,0%	0,98	46	
	VR	OG2	4,43	100%	4,43						
	Wohnen	OG2	17,21	100%	17,21						
	Kochen	OG2	5,04	100%	5,04						
	Bad	OG2	6,11	100%	6,11						
	Zimmer	OG2	11,85	100%	11,85						
	<b>Loggia</b>	OG2	<b>5,06</b>	50%	2,53						
Zuschlag	<b>Balkon</b>	OG2	<b>2,37</b>		2,37		25% vom NW/m <sup>2</sup>		0,25	1	47
Zubehör	<b>ER 3-13</b>	KG	<b>1,35</b>		1,35	0,30			0,30	1	1

<b>Whg-TOP 213</b>	<b>Mindestanteil:</b>	<b>48</b>	<b>von</b>	<b>14538</b>
--------------------	-----------------------	-----------	------------	--------------



<b>Whg-TOP 214</b>	<b>NFI.</b>		<b>75,65</b>		<b>72,92</b>	1,00		0,0%	1,00	73	
	VR	OG2	4,00	100%	4,00						
	Wohn/Ess/Küche	OG2	30,74	100%	30,74						
	Zimmer 1	OG2	11,22	100%	11,22						
	Gang	OG2	3,10	100%	3,10						
	WC	OG2	1,94	100%	1,94						
	Bad	OG2	5,81	100%	5,81						
	AR	OG2	1,44	100%	1,44						
	Zimmer 2	OG2	11,94	100%	11,94						
	<b>Loggia</b>	OG2	<b>5,46</b>	50%	2,73						
Zuschlag	<b>Balkon</b>	OG2	<b>2,56</b>		2,56		25% vom NW/m <sup>2</sup>		0,25	1	74
Zubehör	<b>ER 3-14</b>	KG	<b>1,32</b>		1,32	0,30			0,30	1	1
<b>Whg-TOP 214</b>	<b>Mindestanteil:</b>		<b>75</b>	<b>von</b>	<b>14538</b>						

**Obergeschoß 3**

<b>Whg-TOP 215</b>			<b>32,05</b>		<b>32,05</b>	1,00	A19(-2%)	-2,0%	0,98	31	
	VR/Kochen	OG3	6,99	100%	6,99						
	Bad	OG3	5,75	100%	5,75						
	Wohnen	OG3	19,31	100%	19,31						
Zuschlag	<b>Balkon</b>	OG3	<b>10,47</b>		10,47		25% vom NW/m <sup>2</sup>		0,25	3	34
Zubehör	<b>ER 3-15</b>	KG	<b>1,32</b>		1,32	0,30			0,30	1	1
<b>Whg-TOP 215</b>	<b>Mindestanteil:</b>		<b>35</b>	<b>von</b>	<b>14538</b>						

<b>Whg-TOP 216</b>	<b>NFI.</b>		<b>42,38</b>		<b>37,61</b>	1,00	A19(-2%)	-2,0%	0,98	37	
	VR/Kochen	OG3	7,45	100%	7,45						
	Bad	OG3	6,21	100%	6,21						
	Wohnen	OG3	19,18	100%	19,18						
	<b>Loggia</b>	OG3	<b>9,54</b>	50%	4,77					37	
Zubehör	<b>ER 3-16</b>	KG	<b>1,32</b>		1,32	0,30			0,30	1	1
<b>Whg-TOP 216</b>	<b>Mindestanteil:</b>		<b>38</b>	<b>von</b>	<b>14538</b>						

<b>Whg-TOP 217</b>	<b>NFI.</b>		<b>42,38</b>		<b>37,61</b>	1,00	A19(-2%)	-2,0%	0,98	37	
	VR/Kochen	OG3	7,45	100%	7,45						
	Bad	OG3	6,21	100%	6,21						
	Wohnen	OG3	19,18	100%	19,18						
	<b>Loggia</b>	OG3	<b>9,54</b>	50%	4,77					37	
Zubehör	<b>ER 3-17</b>	KG	<b>1,32</b>		1,32	0,30			0,30	1	1
<b>Whg-TOP 217</b>	<b>Mindestanteil:</b>		<b>38</b>	<b>von</b>	<b>14538</b>						

<b>Whg-TOP 218</b>	<b>NFI.</b>		<b>41,27</b>		<b>37,04</b>	1,00	A19(-2%)	-2,0%	0,98	36	
	VR/Kochen	OG3	7,45	100%	7,45						
	Bad	OG3	6,18	100%	6,18						
	Wohnen	OG3	19,18	100%	19,18						
	<b>Loggia</b>	OG3	<b>8,46</b>	50%	4,23					36	
Zubehör	<b>ER 3-18</b>	KG	<b>1,35</b>		1,35	0,30			0,30	1	1
<b>Whg-TOP 218</b>	<b>Mindestanteil:</b>		<b>37</b>	<b>von</b>	<b>14538</b>						



<b>Whg-TOP 219</b>	<b>NFI.</b>		<b>75,60</b>		<b>72,12</b>	1,00		0,0%	1,00	72	
	VR	OG3	2,22	100%	2,22						
	Wohn/Ess/Küche	OG3	29,61	100%	29,61						
	Gang	OG3	4,68	100%	4,68						
	WC	OG3	1,85	100%	1,85						
	Zimmer	OG3	12,64	100%	12,64						
	Bad	OG3	5,29	100%	5,29						
	Zimmer	OG3	12,35	100%	12,35						
	<b>Loggia</b>	OG3	<b>6,96</b>	50%	3,48					72	
Zubehör	<b>ER 3-19</b>	KG	<b>2,09</b>		2,09	0,30			0,30	1	1

<b>Whg-TOP 219</b>	<b>Mindestanteil:</b>	<b>73</b>	<b>von</b>	<b>14538</b>
--------------------	-----------------------	-----------	------------	--------------

<b>Whg-TOP 220</b>	<b>NFI.</b>		<b>49,70</b>		<b>47,17</b>	1,00	A19(-2%)	-2,0%	0,98	46	
	VR	OG3	4,43	100%	4,43						
	Wohnen	OG3	17,21	100%	17,21						
	Kochen	OG3	5,04	100%	5,04						
	Bad	OG3	6,11	100%	6,11						
	Zimmer	OG3	11,85	100%	11,85						
	<b>Loggia</b>	OG3	<b>5,06</b>	50%	2,53						
Zuschlag	<b>Balkon</b>	OG3	<b>2,37</b>		2,37		25% vom NW/m <sup>2</sup>		0,25	1	47
Zubehör	<b>ER 3-20</b>	KG	<b>2,09</b>		2,09	0,30			0,30	1	1

<b>Whg-TOP 220</b>	<b>Mindestanteil:</b>	<b>48</b>	<b>von</b>	<b>14538</b>
--------------------	-----------------------	-----------	------------	--------------

<b>Whg-TOP 221</b>	<b>NFI.</b>		<b>75,65</b>		<b>72,92</b>	1,00		0,0%	1,00	73	
	VR	OG3	4,00	100%	4,00						
	Wohn/Ess/Küche	OG3	30,74	100%	30,74						
	Zimmer 1	OG3	11,22	100%	11,22						
	Gang	OG3	3,10	100%	3,10						
	WC	OG3	1,94	100%	1,94						
	Bad	OG3	5,81	100%	5,81						
	AR	OG3	1,44	100%	1,44						
	Zimmer 2	OG3	11,94	100%	11,94						
	<b>Loggia</b>	OG3	<b>5,46</b>	50%	2,73						
Zuschlag	<b>Balkon</b>	OG3	<b>2,56</b>		2,56		25% vom NW/m <sup>2</sup>		0,25	1	74
Zubehör	<b>ER 3-21</b>	KG	<b>2,09</b>		2,09	0,30			0,30	1	1

<b>Whg-TOP 221</b>	<b>Mindestanteil:</b>	<b>75</b>	<b>von</b>	<b>14538</b>
--------------------	-----------------------	-----------	------------	--------------

#### Obergeschoß 4

<b>Whg-TOP 222</b>			<b>32,05</b>		<b>32,05</b>	1,00	Z1(+10%), A10(-5%), A19(-2%)	3,0%	1,03	33	
	VR/Kochen	OG4	6,99	100%	6,99						
	Bad	OG4	5,75	100%	5,75						
	Wohnen	OG4	19,31	100%	19,31						
Zuschlag	<b>Balkon</b>	OG4	<b>10,38</b>		10,38		25% vom NW/m <sup>2</sup>		0,26	3	36
Zubehör	<b>ER 3-22</b>	KG	<b>2,09</b>		2,09	0,30			0,30	1	1

<b>Whg-TOP 222</b>	<b>Mindestanteil:</b>	<b>37</b>	<b>von</b>	<b>14538</b>
--------------------	-----------------------	-----------	------------	--------------



<b>Whg-TOP 223</b>	<b>NFI.</b>		<b>42,34</b>		<b>37,59</b>	1,00	Z1(+10%), A10(-5%), A19(-2%)	3,0%	1,03	39
	VR/Kochen	OG4	7,45	100%	7,45					
	Bad	OG4	6,21	100%	6,21					
	Wohnen	OG4	19,18	100%	19,18					
	<b>Loggia</b>	OG4	<b>9,50</b>	50%	4,75					39
Zubehör	<b>ER 3-23</b>	KG	<b>2,09</b>		2,09	0,30			0,30	1 1

<b>Whg-TOP 223</b>	<b>Mindestanteil:</b>	<b>40</b>	<b>von 14538</b>
--------------------	-----------------------	-----------	------------------

<b>Whg-TOP 224</b>	<b>NFI.</b>		<b>42,38</b>		<b>37,61</b>	1,00	Z1(+10%), A10(-5%), A19(-2%)	3,0%	1,03	39
	VR/Kochen	OG4	7,45	100%	7,45					
	Bad	OG4	6,21	100%	6,21					
	Wohnen	OG4	19,18	100%	19,18					
	<b>Loggia</b>	OG4	<b>9,54</b>	50%	4,77					39
Zubehör	<b>ER 4-5</b>	KG	<b>2,01</b>		2,01	0,30			0,30	1 1

<b>Whg-TOP 224</b>	<b>Mindestanteil:</b>	<b>40</b>	<b>von 14538</b>
--------------------	-----------------------	-----------	------------------

<b>Whg-TOP 225</b>	<b>NFI.</b>		<b>41,27</b>		<b>37,04</b>	1,00	Z1(+10%), A10(-5%), A19(-2%)	3,0%	1,03	38
	VR/Kochen	OG4	7,45	100%	7,45					
	Bad	OG4	6,18	100%	6,18					
	Wohnen	OG4	19,18	100%	19,18					
	<b>Loggia</b>	OG4	<b>8,46</b>	50%	4,23					38
Zubehör	<b>ER 4-6</b>	KG	<b>1,92</b>		1,92	0,30			0,30	1 1

<b>Whg-TOP 225</b>	<b>Mindestanteil:</b>	<b>39</b>	<b>von 14538</b>
--------------------	-----------------------	-----------	------------------

<b>Whg-TOP 226</b>	<b>NFI.</b>		<b>75,60</b>		<b>72,12</b>	1,00	Z1(+10%), A10(-5%)	5,0%	1,05	76
	VR	OG4	2,22	100%	2,22					
	Wohn/Ess/Küche	OG4	29,61	100%	29,61					
	Gang	OG4	4,68	100%	4,68					
	WC	OG4	1,85	100%	1,85					
	Zimmer	OG4	12,64	100%	12,64					
	Bad	OG4	5,29	100%	5,29					
	Zimmer	OG4	12,35	100%	12,35					
	<b>Loggia</b>	OG4	<b>6,96</b>	50%	3,48					76
Zubehör	<b>ER 4-7</b>	KG	<b>1,92</b>		1,92	0,30			0,30	1 1

<b>Whg-TOP 226</b>	<b>Mindestanteil:</b>	<b>77</b>	<b>von 14538</b>
--------------------	-----------------------	-----------	------------------

<b>Whg-TOP 227</b>	<b>NFI.</b>		<b>49,70</b>		<b>47,17</b>	1,00	Z1(+10%), A10(-5%), A19(-2%)	3,0%	1,03	49
	VR	OG4	4,43	100%	4,43					
	Wohnen	OG4	17,21	100%	17,21					
	Kochen	OG4	5,04	100%	5,04					
	Bad	OG4	6,11	100%	6,11					
	Zimmer	OG4	11,85	100%	11,85					
	<b>Loggia</b>	OG4	<b>5,06</b>	50%	2,53					
Zuschlag	<b>Balkon</b>	OG4	<b>2,37</b>		2,37		25% vom NW/m <sup>2</sup>		0,26	1 50
Zubehör	<b>ER 4-8</b>	KG	<b>1,92</b>		1,92	0,30			0,30	1 1

<b>Whg-TOP 227</b>	<b>Mindestanteil:</b>	<b>51</b>	<b>von 14538</b>
--------------------	-----------------------	-----------	------------------





<b>Whg-TOP 228</b>	<b>NFI.</b>		<b>75,65</b>		<b>72,92</b>	1,00	Z1(+10%), A10(-5%)	5,0%	1,05	77
	VR	OG4	4,00	100%	4,00					
	Wohn/Ess/Küche	OG4	30,74	100%	30,74					
	Zimmer 1	OG4	11,22	100%	11,22					
	Gang	OG4	3,10	100%	3,10					
	WC	OG4	1,94	100%	1,94					
	Bad	OG4	5,81	100%	5,81					
	AR	OG4	1,44	100%	1,44					
	Zimmer 2	OG4	11,94	100%	11,94					
	<b>Loggia</b>	OG4	<b>5,46</b>	50%	2,73					
Zuschlag	<b>Balkon</b>	OG4	<b>2,56</b>		2,56		25% vom NW/m <sup>2</sup>		0,26	1 78
Zubehör	<b>ER 4-9</b>	KG	<b>1,87</b>		1,87	0,30			0,30	1 1

<b>Whg-TOP 228</b>	<b>Mindestanteil:</b>	<b>79</b>	<b>von</b>	<b>14538</b>
--------------------	-----------------------	-----------	------------	--------------

### STIEGE 3

#### Erdgeschoss

<b>Whg-TOP 301</b>	<b>NFI.</b>		<b>89,07</b>		<b>89,07</b>	1,00	A3(-5%), A19(-2%), Z5(+5%)	-2,0%	0,98	87
	VR	EG	8,78	100%	8,78					
	Gang	EG	6,55	100%	6,55					
	Bad	EG	6,07	100%	6,07					
	Bad/WC	EG	4,94	100%	4,94					
	AR	EG	1,12	100%	1,12					
	Zimmer 1	EG	11,41	100%	11,41					
	Zimmer 2	EG	13,32	100%	13,32					
	Zimmer 1	EG	10,87	100%	10,87					
	Wohnen	EG	18,69	100%	18,69					
	Kochen	EG	7,32	100%	7,32					
Zuschlag	<b>Terrasse</b>	EG	<b>24,55</b>		24,55		25% vom NW/m <sup>2</sup>		0,25	6 93
Zubehör	<b>Garten Top 301</b>	EG	<b>162,19</b>		162,19	0,10			0,10	16
Zubehör	<b>ER 1-1</b>	KG	<b>1,91</b>		1,91	0,30			0,30	1 17

<b>Whg-TOP 301</b>	<b>Mindestanteil:</b>	<b>110</b>	<b>von</b>	<b>14538</b>
--------------------	-----------------------	------------	------------	--------------

<b>Whg-TOP 302</b>	<b>NFI.</b>		<b>89,97</b>		<b>89,97</b>	1,00	A3(-5%), A19(-2%), Z5(+5%)	-2,0%	0,98	88
	VR	EG	8,76	100%	8,76					
	Gang	EG	6,55	100%	6,55					
	Bad	EG	6,17	100%	6,17					
	Bad/WC	EG	4,94	100%	4,94					
	AR	EG	1,12	100%	1,12					
	Zimmer 1	EG	11,00	100%	11,00					
	Zimmer 2	EG	13,69	100%	13,69					
	Zimmer 3	EG	11,55	100%	11,55					
	Wohnen	EG	18,87	100%	18,87					
	Kochen	EG	7,32	100%	7,32					
Zuschlag	<b>Terrasse</b>	EG	<b>6,29</b>		6,29		25% vom NW/m <sup>2</sup>		0,25	2 90
Zubehör	<b>Garten Top 302</b>	EG	<b>51,51</b>		51,51	0,10			0,10	5
Zubehör	<b>ER 1-2</b>	KG	<b>1,91</b>		1,91	0,30			0,30	1 6

<b>Whg-TOP 302</b>	<b>Mindestanteil:</b>	<b>96</b>	<b>von</b>	<b>14538</b>
--------------------	-----------------------	-----------	------------	--------------



<b>Whg-TOP 303</b>	<b>NFI.</b>		<b>67,27</b>		<b>67,27</b>	1,00	A3(-5%)	-5,0%	0,95	64
	VR	EG	8,25	100%	8,25					
	WC	EG	2,03	100%	2,03					
	Gang	EG	2,06	100%	2,06					
	AR	EG	1,68	100%	1,68					
	Bad	EG	5,62	100%	5,62					
	Zimmer 1	EG	10,64	100%	10,64					
	Zimmer 2	EG	12,29	100%	12,29					
	Wohnen	EG	19,62	100%	19,62					
	Kochen	EG	5,08	100%	5,08					
Zuschlag	<b>Terrasse</b>	EG	<b>6,51</b>		6,51		25% vom NW/m <sup>2</sup>		0,24	2
Zubehör	<b>Garten Top 303</b>	EG	<b>23,50</b>		23,50	0,10			0,10	2
<b>Whg-TOP 303</b>		<b>Mindestanteil:</b>		<b>68</b>	<b>von 14538</b>					

<b>Whg-TOP 304</b>	<b>NFI.</b>		<b>67,35</b>		<b>67,35</b>	1,00	A3(-5%)	-5,0%	0,95	64
	VR	EG	8,33	100%	8,33					
	WC	EG	2,03	100%	2,03					
	Gang	EG	2,06	100%	2,06					
	AR	EG	1,68	100%	1,68					
	Bad	EG	5,62	100%	5,62					
	Zimmer 1	EG	10,64	100%	10,64					
	Zimmer 2	EG	12,29	100%	12,29					
	Wohnen	EG	19,62	100%	19,62					
	Kochen	EG	5,08	100%	5,08					
Zuschlag	<b>Terrasse</b>	EG	<b>6,51</b>		6,51		25% vom NW/m <sup>2</sup>		0,24	2
Zubehör	<b>Garten Top 304</b>	EG	<b>24,41</b>		24,41	0,10			0,10	2
<b>Whg-TOP 304</b>		<b>Mindestanteil:</b>		<b>68</b>	<b>von 14538</b>					

**Obergeschoß 1**

<b>Whg-TOP 305</b>	<b>NFI.</b>		<b>66,65</b>		<b>66,65</b>	1,00		0,0%	1,00	67
	VR	OG1	7,89	100%	7,89					
	WC	OG1	2,03	100%	2,03					
	Zimmer 2	OG1	10,43	100%	10,43					
	Wohnen	OG1	19,89	100%	19,89					
	Kochen	OG1	5,08	100%	5,08					
	Gang	OG1	2,11	100%	2,11					
	Bad	OG1	5,52	100%	5,52					
	AR	OG1	1,62	100%	1,62					
	Zimmer 1	OG1	12,08	100%	12,08					
Zuschlag	<b>Balkon</b>	OG1	<b>6,06</b>		6,06		25% vom NW/m <sup>2</sup>		0,25	2
Zubehör	<b>ER 1-3</b>	KG	<b>1,91</b>		1,91	0,30			0,30	1
<b>Whg-TOP 305</b>		<b>Mindestanteil:</b>		<b>70</b>	<b>von 14538</b>					

<b>Whg-TOP 306</b>			<b>44,77</b>		<b>44,77</b>	1,00	A19(-2%)	-2,0%	0,98	44
	Bad/WC	OG1	6,65	100%	6,65					
	Zimmer	OG1	12,15	100%	12,15					
	Wohnen	OG1	16,43	100%	16,43					
	Kochen	OG1	9,54	100%	9,54					
Zuschlag	<b>Balkon</b>	OG1	<b>6,06</b>		6,06		25% vom NW/m <sup>2</sup>		0,25	1
Zubehör	<b>ER 1-4</b>	KG	<b>1,91</b>		1,91	0,30			0,30	1
<b>Whg-TOP 306</b>		<b>Mindestanteil:</b>		<b>46</b>	<b>von 14538</b>					



Whg-TOP 307	NFI.		90,70		90,70	1,00	A19(-2%), Z5(+5%)	3,0%	1,03	93	
	VR	OG1	8,78	100%	8,78						
	Gang	OG1	6,55	100%	6,55						
	Bad	OG1	6,17	100%	6,17						
	Bad/WC	OG1	4,94	100%	4,94						
	AR	OG1	1,20	100%	1,20						
	Zimmer 1	OG1	11,82	100%	11,82						
	Zimmer 2	OG1	13,69	100%	13,69						
	Zimmer 1	OG1	11,00	100%	11,00						
	Wohnen	OG1	19,13	100%	19,13						
	Kochen	OG1	7,42	100%	7,42						
Zuschlag	<b>Balkon</b>	OG1	<b>13,26</b>		13,26		25% vom NW/m <sup>2</sup>		0,26	3	96
Zubehör	<b>ER 1-5</b>	KG	<b>1,91</b>		1,91	0,30			0,30	1	1

<b>Whg-TOP 307</b>	<b>Mindestanteil:</b>	<b>97</b>	<b>von</b>	<b>14538</b>
--------------------	-----------------------	-----------	------------	--------------

Whg-TOP 308	NFI.		90,36		90,36	1,00	A19(-2%), Z5(+5%)	3,0%	1,03	93	
	VR	OG1	8,78	100%	8,78						
	Gang	OG1	6,55	100%	6,55						
	Bad	OG1	6,17	100%	6,17						
	Bad/WC	OG1	4,94	100%	4,94						
	AR	OG1	1,12	100%	1,12						
	Zimmer 1	OG1	11,00	100%	11,00						
	Zimmer 2	OG1	13,69	100%	13,69						
	Zimmer 3	OG1	11,55	100%	11,55						
	Wohnen	OG1	19,14	100%	19,14						
	Kochen	OG1	7,42	100%	7,42						
Zuschlag	<b>Balkon</b>	OG1	<b>13,26</b>		13,26		25% vom NW/m <sup>2</sup>		0,26	3	96
Zubehör	<b>ER 1-6</b>	KG	<b>1,70</b>		1,70	0,30			0,30	1	1

<b>Whg-TOP 308</b>	<b>Mindestanteil:</b>	<b>97</b>	<b>von</b>	<b>14538</b>
--------------------	-----------------------	-----------	------------	--------------

Whg-TOP 309	NFI.		67,34		67,34	1,00		0,0%	1,00	67	
	VR	OG1	8,33	100%	8,33						
	WC	OG1	2,03	100%	2,03						
	Gang	OG1	2,05	100%	2,05						
	AR	OG1	1,68	100%	1,68						
	Bad	OG1	5,62	100%	5,62						
	Zimmer 1	OG1	10,64	100%	10,64						
	Zimmer 2	OG1	12,29	100%	12,29						
	Wohnen	OG1	19,62	100%	19,62						
	Kochen	OG1	5,08	100%	5,08						
Zuschlag	<b>Balkon</b>	OG1	<b>6,06</b>		6,06		25% vom NW/m <sup>2</sup>		0,25	2	69
Zubehör	<b>ER 1-7</b>	KG	<b>1,63</b>		1,63	0,30			0,30	1	1

<b>Whg-TOP 309</b>	<b>Mindestanteil:</b>	<b>70</b>	<b>von</b>	<b>14538</b>
--------------------	-----------------------	-----------	------------	--------------



Whg-TOP 310	NFI.		67,34		67,34	1,00		0,0%	1,00	67	
	VR	OG1	8,33	100%	8,33						
	WC	OG1	2,03	100%	2,03						
	Gang	OG1	2,05	100%	2,05						
	AR	OG1	1,68	100%	1,68						
	Bad	OG1	5,62	100%	5,62						
	Zimmer 1	OG1	10,64	100%	10,64						
	Zimmer 2	OG1	12,29	100%	12,29						
	Wohnen	OG1	19,62	100%	19,62						
	Kochen	OG1	5,08	100%	5,08						
Zuschlag	<b>Balkon</b>	OG1	<b>6,06</b>		6,06		25% vom NW/m <sup>2</sup>		0,25	2	69
Zubehör	<b>ER 1-8</b>	KG	<b>1,70</b>		1,70	0,30			0,30	1	1

<b>Whg-TOP 310</b>	<b>Mindestanteil:</b>	<b>70</b>	<b>von</b>	<b>14538</b>
--------------------	-----------------------	-----------	------------	--------------

Whg-TOP 311	NFI.		67,61		67,61	1,00	A8(-5%)	-5,0%	0,95	64	
	VR	OG1	8,24	100%	8,24						
	WC	OG1	2,07	100%	2,07						
	Gang	OG1	2,10	100%	2,10						
	AR	OG1	1,68	100%	1,68						
	Bad	OG1	5,69	100%	5,69						
	Zimmer 1	OG1	10,47	100%	10,47						
	Zimmer 2	OG1	12,45	100%	12,45						
	Wohnen	OG1	19,83	100%	19,83						
	Kochen	OG1	5,08	100%	5,08						
Zuschlag	<b>Balkon</b>	OG1	<b>6,06</b>		6,06		25% vom NW/m <sup>2</sup>		0,24	1	65
Zubehör	<b>ER 1-9</b>	KG	<b>1,61</b>		1,61	0,30			0,30	1	1

<b>Whg-TOP 311</b>	<b>Mindestanteil:</b>	<b>66</b>	<b>von</b>	<b>14538</b>
--------------------	-----------------------	-----------	------------	--------------

Whg-TOP 312	NFI.		70,43		70,43	1,00	A8(-5%)	-5,0%	0,95	67	
	VR	OG1	6,88	100%	6,88						
	WC	OG1	1,85	100%	1,85						
	Gang	OG1	1,92	100%	1,92						
	AR	OG1	2,15	100%	2,15						
	Bad	OG1	7,67	100%	7,67						
	Zimmer 1	OG1	11,18	100%	11,18						
	Zimmer 2	OG1	15,41	100%	15,41						
	Wohnen	OG1	17,09	100%	17,09						
	Kochen	OG1	6,28	100%	6,28						
Zuschlag	<b>Balkon</b>	OG1	<b>6,06</b>		6,06		25% vom NW/m <sup>2</sup>		0,24	1	68
Zubehör	<b>ER 1-10</b>	KG	<b>1,61</b>		1,61	0,30			0,30	1	1

<b>Whg-TOP 312</b>	<b>Mindestanteil:</b>	<b>69</b>	<b>von</b>	<b>14538</b>
--------------------	-----------------------	-----------	------------	--------------



**Obergeschoß 2**

<b>Whg-TOP 313</b>	<b>NFI.</b>		<b>67,48</b>		<b>67,48</b>	1,00		0,0%	1,00	67	
	VR	OG2	8,47	100%	8,47						
	WC	OG2	2,03	100%	2,03						
	Zimmer 2	OG2	10,64	100%	10,64						
	Wohnen	OG2	19,62	100%	19,62						
	Kochen	OG2	5,08	100%	5,08						
	Gang	OG2	2,05	100%	2,05						
	Bad	OG2	5,62	100%	5,62						
	AR	OG2	1,68	100%	1,68						
	Zimmer 1	OG2	12,29	100%	12,29						
Zuschlag	<b>Balkon</b>	OG2	<b>6,06</b>		6,06		25% vom NW/m <sup>2</sup>		0,25	2	69
Zubehör	<b>ER 1-11</b>	KG	<b>1,61</b>		1,61	0,30			0,30	1	1

<b>Whg-TOP 313</b>	<b>Mindestanteil:</b>	<b>70</b>	<b>von</b>	<b>14538</b>
--------------------	-----------------------	-----------	------------	--------------

<b>Whg-TOP 314</b>			<b>44,77</b>		<b>44,77</b>	1,00	A19(-2%)	-2,0%	0,98	44	
	Bad/WC	OG2	6,65	100%	6,65						
	Zimmer	OG2	12,15	100%	12,15						
	Wohnen	OG2	16,43	100%	16,43						
	Kochen	OG2	9,54	100%	9,54						
Zuschlag	<b>Balkon</b>	OG2	<b>6,06</b>		6,06		25% vom NW/m <sup>2</sup>		0,25	1	45
Zubehör	<b>ER 1-12</b>	KG	<b>1,61</b>		1,61	0,30			0,30	1	1

<b>Whg-TOP 314</b>	<b>Mindestanteil:</b>	<b>46</b>	<b>von</b>	<b>14538</b>
--------------------	-----------------------	-----------	------------	--------------

<b>Whg-TOP 315</b>	<b>NFI.</b>		<b>90,70</b>		<b>90,70</b>	1,00	A19(-2%), Z5(+5%)	3,0%	1,03	93	
	VR	OG2	8,78	100%	8,78						
	Gang	OG2	6,55	100%	6,55						
	Bad	OG2	6,17	100%	6,17						
	Bad/WC	OG2	4,94	100%	4,94						
	AR	OG2	1,20	100%	1,20						
	Zimmer 1	OG2	11,82	100%	11,82						
	Zimmer 2	OG2	13,69	100%	13,69						
	Zimmer 1	OG2	11,00	100%	11,00						
	Wohnen	OG2	19,13	100%	19,13						
	Kochen	OG2	7,42	100%	7,42						
Zuschlag	<b>Balkon</b>	OG2	<b>13,26</b>		13,26		25% vom NW/m <sup>2</sup>		0,26	3	96
Zubehör	<b>ER 1-13</b>	KG	<b>1,61</b>		1,61	0,30			0,30	1	1

<b>Whg-TOP 315</b>	<b>Mindestanteil:</b>	<b>97</b>	<b>von</b>	<b>14538</b>
--------------------	-----------------------	-----------	------------	--------------



Whg-TOP 316	NFI.		90,36		90,36	1,00	A19(-2%), Z5(+5%)	3,0%	1,03	93	
	VR	OG2	8,78	100%	8,78						
	Gang	OG2	6,55	100%	6,55						
	Bad	OG2	6,17	100%	6,17						
	Bad/WC	OG2	4,94	100%	4,94						
	AR	OG2	1,12	100%	1,12						
	Zimmer 1	OG2	11,00	100%	11,00						
	Zimmer 2	OG2	13,69	100%	13,69						
	Zimmer 3	OG2	11,55	100%	11,55						
	Wohnen	OG2	19,14	100%	19,14						
	Kochen	OG2	7,42	100%	7,42						
Zuschlag	<b>Balkon</b>	OG2	<b>13,26</b>		13,26		25% vom NW/m <sup>2</sup>		0,26	3	96
Zubehör	<b>ER 1-14</b>	KG	<b>1,61</b>		1,61	0,30			0,30	1	1

<b>Whg-TOP 316</b>	<b>Mindestanteil:</b>	<b>97</b>	<b>von</b>	<b>14538</b>
--------------------	-----------------------	-----------	------------	--------------

Whg-TOP 317	NFI.		67,31		67,31	1,00		0,0%	1,00	67	
	VR	OG2	8,33	100%	8,33						
	WC	OG2	2,03	100%	2,03						
	Gang	OG2	2,05	100%	2,05						
	AR	OG2	1,68	100%	1,68						
	Bad	OG2	5,62	100%	5,62						
	Zimmer 1	OG2	10,64	100%	10,64						
	Zimmer 2	OG2	12,29	100%	12,29						
	Wohnen	OG2	19,59	100%	19,59						
	Kochen	OG2	5,08	100%	5,08						
Zuschlag	<b>Balkon</b>	OG2	<b>6,06</b>		6,06		25% vom NW/m <sup>2</sup>		0,25	2	69
Zubehör	<b>ER 1-15</b>	KG	<b>1,60</b>		1,60	0,30			0,30	1	1

<b>Whg-TOP 317</b>	<b>Mindestanteil:</b>	<b>70</b>	<b>von</b>	<b>14538</b>
--------------------	-----------------------	-----------	------------	--------------

Whg-TOP 318	NFI.		67,34		67,34	1,00		0,0%	1,00	67	
	VR	OG2	8,33	100%	8,33						
	WC	OG2	2,03	100%	2,03						
	Gang	OG2	2,05	100%	2,05						
	AR	OG2	1,68	100%	1,68						
	Bad	OG2	5,62	100%	5,62						
	Zimmer 1	OG2	10,64	100%	10,64						
	Zimmer 2	OG2	12,29	100%	12,29						
	Wohnen	OG2	19,62	100%	19,62						
	Kochen	OG2	5,08	100%	5,08						
Zuschlag	<b>Balkon</b>	OG2	<b>6,06</b>		6,06		25% vom NW/m <sup>2</sup>		0,25	2	69
Zubehör	<b>ER 1-16</b>	KG	<b>1,60</b>		1,60	0,30			0,30	1	1

<b>Whg-TOP 318</b>	<b>Mindestanteil:</b>	<b>70</b>	<b>von</b>	<b>14538</b>
--------------------	-----------------------	-----------	------------	--------------



<b>Whg-TOP 319</b>	<b>NFI.</b>		<b>67,62</b>		<b>67,62</b>	1,00		0,0%	1,00	68
	VR	OG2	8,25	100%	8,25					
	WC	OG2	2,05	100%	2,05					
	Gang	OG2	2,10	100%	2,10					
	AR	OG2	1,68	100%	1,68					
	Bad	OG2	5,69	100%	5,69					
	Zimmer 1	OG2	10,47	100%	10,47					
	Zimmer 2	OG2	12,45	100%	12,45					
	Wohnen	OG2	19,83	100%	19,83					
	Kochen	OG2	5,10	100%	5,10					
Zuschlag	<b>Balkon</b>	OG2	<b>6,06</b>		6,06		25% vom NW/m <sup>2</sup>		0,25	2
Zubehör	<b>ER 1-17</b>	KG	<b>1,60</b>		1,60	0,30			0,30	1

<b>Whg-TOP 319</b>	<b>Mindestanteil:</b>	<b>71</b>	<b>von</b>	<b>14538</b>
--------------------	-----------------------	-----------	------------	--------------

<b>Whg-TOP 320</b>	<b>NFI.</b>		<b>70,41</b>		<b>70,41</b>	1,00		0,0%	1,00	70
	VR	OG2	6,88	100%	6,88					
	WC	OG2	1,85	100%	1,85					
	Gang	OG2	1,92	100%	1,92					
	AR	OG2	2,13	100%	2,13					
	Bad	OG2	7,67	100%	7,67					
	Zimmer 1	OG2	11,18	100%	11,18					
	Zimmer 2	OG2	15,41	100%	15,41					
	Wohnen	OG2	17,09	100%	17,09					
	Kochen	OG2	6,28	100%	6,28					
Zuschlag	<b>Balkon</b>	OG2	<b>6,06</b>		6,06		25% vom NW/m <sup>2</sup>		0,25	2
Zubehör	<b>ER 1-18</b>	KG	<b>1,60</b>		1,60	0,30			0,30	1

<b>Whg-TOP 320</b>	<b>Mindestanteil:</b>	<b>73</b>	<b>von</b>	<b>14538</b>
--------------------	-----------------------	-----------	------------	--------------

**Obergeschoß 3**

<b>Whg-TOP 321</b>	<b>NFI.</b>		<b>67,34</b>		<b>67,34</b>	1,00		0,0%	1,00	67
	VR	OG3	8,33	100%	8,33					
	WC	OG3	2,03	100%	2,03					
	Zimmer 2	OG3	10,64	100%	10,64					
	Wohnen	OG3	19,62	100%	19,62					
	Kochen	OG3	5,08	100%	5,08					
	Gang	OG3	2,05	100%	2,05					
	Bad	OG3	5,62	100%	5,62					
	AR	OG3	1,68	100%	1,68					
	Zimmer 1	OG3	12,29	100%	12,29					
Zuschlag	<b>Balkon</b>	OG3	<b>6,06</b>		6,06		25% vom NW/m <sup>2</sup>		0,25	2
Zubehör	<b>ER 1-19</b>	KG	<b>1,60</b>		1,60	0,30			0,30	1

<b>Whg-TOP 321</b>	<b>Mindestanteil:</b>	<b>70</b>	<b>von</b>	<b>14538</b>
--------------------	-----------------------	-----------	------------	--------------

<b>Whg-TOP 322</b>			<b>44,77</b>		<b>44,77</b>	1,00	A19(-2%)	-2,0%	0,98	44
	Bad/WC	OG3	6,65	100%	6,65					
	Zimmer	OG3	12,15	100%	12,15					
	Wohnen	OG3	16,43	100%	16,43					
	Kochen	OG3	9,54	100%	9,54					
Zuschlag	<b>Balkon</b>	OG3	<b>6,06</b>		6,06		25% vom NW/m <sup>2</sup>		0,25	1
Zubehör	<b>ER 1-20</b>	KG	<b>1,64</b>		1,64	0,30			0,30	1

<b>Whg-TOP 322</b>	<b>Mindestanteil:</b>	<b>46</b>	<b>von</b>	<b>14538</b>
--------------------	-----------------------	-----------	------------	--------------



Whg-TOP 323	NFI.		90,70		90,70	1,00	A19(-2%), Z5(+5%)	3,0%	1,03	93	
	VR	OG3	8,78	100%	8,78						
	Gang	OG3	6,55	100%	6,55						
	Bad	OG3	6,17	100%	6,17						
	Bad/WC	OG3	4,94	100%	4,94						
	AR	OG3	1,20	100%	1,20						
	Zimmer 1	OG3	11,82	100%	11,82						
	Zimmer 2	OG3	13,69	100%	13,69						
	Zimmer 1	OG3	11,00	100%	11,00						
	Wohnen	OG3	19,13	100%	19,13						
	Kochen	OG3	7,42	100%	7,42						
Zuschlag	<b>Balkon</b>	OG3	<b>13,26</b>		13,26		25% vom NW/m <sup>2</sup>		0,26	3	96
Zubehör	<b>ER 1-21</b>	KG	<b>1,57</b>		1,57	0,30			0,30	1	1

<b>Whg-TOP 323</b>	<b>Mindestanteil:</b>	<b>97</b>	<b>von</b>	<b>14538</b>
--------------------	-----------------------	-----------	------------	--------------

Whg-TOP 324	NFI.		90,36		90,36	1,00	A19(-2%), Z5(+5%)	3,0%	1,03	93	
	VR	OG3	8,78	100%	8,78						
	Gang	OG3	6,55	100%	6,55						
	Bad	OG3	6,17	100%	6,17						
	Bad/WC	OG3	4,94	100%	4,94						
	AR	OG3	1,12	100%	1,12						
	Zimmer 1	OG3	11,00	100%	11,00						
	Zimmer 2	OG3	13,69	100%	13,69						
	Zimmer 3	OG3	11,55	100%	11,55						
	Wohnen	OG3	19,14	100%	19,14						
	Kochen	OG3	7,42	100%	7,42						
Zuschlag	<b>Balkon</b>	OG3	<b>13,26</b>		13,26		25% vom NW/m <sup>2</sup>		0,26	3	96
Zubehör	<b>ER 1-22</b>	KG	<b>1,58</b>		1,58	0,30			0,30	1	1

<b>Whg-TOP 324</b>	<b>Mindestanteil:</b>	<b>97</b>	<b>von</b>	<b>14538</b>
--------------------	-----------------------	-----------	------------	--------------

Whg-TOP 325	NFI.		67,31		67,31	1,00		0,0%	1,00	67	
	VR	OG3	8,33	100%	8,33						
	WC	OG3	2,03	100%	2,03						
	Gang	OG3	2,05	100%	2,05						
	AR	OG3	1,68	100%	1,68						
	Bad	OG3	5,62	100%	5,62						
	Zimmer 1	OG3	10,64	100%	10,64						
	Zimmer 2	OG3	12,29	100%	12,29						
	Wohnen	OG3	19,59	100%	19,59						
	Kochen	OG3	5,08	100%	5,08						
Zuschlag	<b>Balkon</b>	OG3	<b>6,06</b>		6,06		25% vom NW/m <sup>2</sup>		0,25	2	69
Zubehör	<b>ER 1-23</b>	KG	<b>1,58</b>		1,58	0,30			0,30	1	1

<b>Whg-TOP 325</b>	<b>Mindestanteil:</b>	<b>70</b>	<b>von</b>	<b>14538</b>
--------------------	-----------------------	-----------	------------	--------------





<b>Whg-TOP 326</b>	<b>NFI.</b>		<b>67,34</b>		<b>67,34</b>	1,00		0,0%	1,00	67	
	VR	OG3	8,33	100%	8,33						
	WC	OG3	2,03	100%	2,03						
	Gang	OG3	2,05	100%	2,05						
	AR	OG3	1,68	100%	1,68						
	Bad	OG3	5,62	100%	5,62						
	Zimmer 1	OG3	10,64	100%	10,64						
	Zimmer 2	OG3	12,29	100%	12,29						
	Wohnen	OG3	19,62	100%	19,62						
	Kochen	OG3	5,08	100%	5,08						
Zuschlag	<b>Balkon</b>	OG3	<b>6,06</b>		6,06		25% vom NW/m <sup>2</sup>		0,25	2	69
Zubehör	<b>ER 1-24</b>	KG	<b>1,58</b>		1,58	0,30			0,30	1	1

<b>Whg-TOP 326</b>	<b>Mindestanteil:</b>	<b>70</b>	<b>von</b>	<b>14538</b>
--------------------	-----------------------	-----------	------------	--------------

<b>Whg-TOP 327</b>	<b>NFI.</b>		<b>67,62</b>		<b>67,62</b>	1,00		0,0%	1,00	68	
	VR	OG3	8,25	100%	8,25						
	WC	OG3	2,05	100%	2,05						
	Gang	OG3	2,10	100%	2,10						
	AR	OG3	1,68	100%	1,68						
	Bad	OG3	5,69	100%	5,69						
	Zimmer 1	OG3	10,47	100%	10,47						
	Zimmer 2	OG3	12,45	100%	12,45						
	Wohnen	OG3	19,83	100%	19,83						
	Kochen	OG3	5,10	100%	5,10						
Zuschlag	<b>Balkon</b>	OG3	<b>6,06</b>		6,06		25% vom NW/m <sup>2</sup>		0,25	2	70
Zubehör	<b>ER 1-25</b>	KG	<b>1,58</b>		1,58	0,30			0,30	1	1

<b>Whg-TOP 327</b>	<b>Mindestanteil:</b>	<b>71</b>	<b>von</b>	<b>14538</b>
--------------------	-----------------------	-----------	------------	--------------

<b>Whg-TOP 328</b>	<b>NFI.</b>		<b>70,43</b>		<b>70,43</b>	1,00		0,0%	1,00	70	
	VR	OG3	6,88	100%	6,88						
	WC	OG3	1,85	100%	1,85						
	Gang	OG3	1,92	100%	1,92						
	AR	OG3	2,15	100%	2,15						
	Bad	OG3	7,67	100%	7,67						
	Zimmer 1	OG3	11,18	100%	11,18						
	Zimmer 2	OG3	15,41	100%	15,41						
	Wohnen	OG3	17,09	100%	17,09						
	Kochen	OG3	6,28	100%	6,28						
Zuschlag	<b>Balkon</b>	OG3	<b>6,06</b>		6,06		25% vom NW/m <sup>2</sup>		0,25	2	72
Zubehör	<b>ER 1-26</b>	KG	<b>1,56</b>		1,56	0,30			0,30	1	1

<b>Whg-TOP 328</b>	<b>Mindestanteil:</b>	<b>73</b>	<b>von</b>	<b>14538</b>
--------------------	-----------------------	-----------	------------	--------------



**Obergeschoß 4**

<b>Whg-TOP 329</b>	<b>NFI.</b>		<b>67,34</b>		<b>67,34</b>	1,00	Z1(+10%), A10(-5%)	5,0%	1,05	71	
	VR	OG4	8,06	100%	8,06						
	WC	OG4	2,03	100%	2,03						
	Zimmer 2	OG4	10,64	100%	10,64						
	Wohnen	OG4	19,89	100%	19,89						
	Kochen	OG4	5,08	100%	5,08						
	Gang	OG4	2,05	100%	2,05						
	Bad	OG4	5,62	100%	5,62						
	AR	OG4	1,68	100%	1,68						
	Zimmer 1	OG4	12,29	100%	12,29						
Zuschlag	<b>Balkon</b>	OG4	<b>6,06</b>		6,06		25% vom NW/m <sup>2</sup>		0,26	2	73
Zubehör	<b>ER 1-27</b>	KG	<b>1,93</b>		1,93	0,30			0,30	1	1

<b>Whg-TOP 329</b>	<b>Mindestanteil:</b>	<b>74</b>	<b>von</b>	<b>14538</b>
--------------------	-----------------------	-----------	------------	--------------

<b>Whg-TOP 330</b>			<b>44,77</b>		<b>44,77</b>	1,00	Z1(+10%), A10(-5%), A19(-2%)	3,0%	1,03	46	
	Bad/WC	OG4	6,65	100%	6,65						
	Zimmer	OG4	12,15	100%	12,15						
	Wohnen	OG4	16,43	100%	16,43						
	Kochen	OG4	9,54	100%	9,54						
Zuschlag	<b>Balkon</b>	OG4	<b>6,06</b>		6,06		25% vom NW/m <sup>2</sup>		0,26	2	48
Zubehör	<b>ER 1-28</b>	KG	<b>1,93</b>		1,93	0,30			0,30	1	1

<b>Whg-TOP 330</b>	<b>Mindestanteil:</b>	<b>49</b>	<b>von</b>	<b>14538</b>
--------------------	-----------------------	-----------	------------	--------------

<b>Whg-TOP 331</b>	<b>NFI.</b>		<b>90,70</b>		<b>90,70</b>	1,00	Z1(+10%), A10(-5%), A19(-2%), Z5(+5%)	8,0%	1,08	98	
	VR	OG4	8,78	100%	8,78						
	Gang	OG4	6,55	100%	6,55						
	Bad	OG4	6,17	100%	6,17						
	Bad/WC	OG4	4,94	100%	4,94						
	AR	OG4	1,20	100%	1,20						
	Zimmer 1	OG4	11,82	100%	11,82						
	Zimmer 2	OG4	13,69	100%	13,69						
	Zimmer 1	OG4	11,00	100%	11,00						
	Wohnen	OG4	19,13	100%	19,13						
	Kochen	OG4	7,42	100%	7,42						
Zuschlag	<b>Balkon</b>	OG4	<b>13,26</b>		13,26		25% vom NW/m <sup>2</sup>		0,27	4	102
Zubehör	<b>ER 1-29</b>	KG	<b>1,94</b>		1,94	0,30			0,30	1	1

<b>Whg-TOP 331</b>	<b>Mindestanteil:</b>	<b>103</b>	<b>von</b>	<b>14538</b>
--------------------	-----------------------	------------	------------	--------------



<b>Whg-TOP 332</b>	<b>NFI.</b>		<b>90,36</b>		<b>90,36</b>	1,00	Z1(+10%), A10(-5%), A19(-2%), Z5(+5%)	8,0%	1,08	98	
	VR	OG4	8,78	100%	8,78						
	Gang	OG4	6,55	100%	6,55						
	Bad	OG4	6,17	100%	6,17						
	Bad/WC	OG4	4,94	100%	4,94						
	AR	OG4	1,12	100%	1,12						
	Zimmer 1	OG4	11,00	100%	11,00						
	Zimmer 2	OG4	13,69	100%	13,69						
	Zimmer 3	OG4	11,55	100%	11,55						
	Wohnen	OG4	19,14	100%	19,14						
	Kochen	OG4	7,42	100%	7,42						
Zuschlag	<b>Balkon</b>	OG4	<b>13,26</b>		13,26		25% vom NW/m <sup>2</sup>		0,27	4	102
Zubehör	<b>ER 1-30</b>	KG	<b>1,64</b>		1,64	0,30			0,30	1	1

<b>Whg-TOP 332</b>	<b>Mindestanteil:</b>	<b>103</b>	<b>von</b>	<b>14538</b>
--------------------	-----------------------	------------	------------	--------------

<b>Whg-TOP 333</b>	<b>NFI.</b>		<b>67,34</b>		<b>67,34</b>	1,00	Z1(+10%), A10(-5%)	5,0%	1,05	71	
	VR	OG4	8,33	100%	8,33						
	WC	OG4	2,03	100%	2,03						
	Gang	OG4	2,05	100%	2,05						
	AR	OG4	1,68	100%	1,68						
	Bad	OG4	5,62	100%	5,62						
	Zimmer 1	OG4	10,64	100%	10,64						
	Zimmer 2	OG4	12,29	100%	12,29						
	Wohnen	OG4	19,62	100%	19,62						
	Kochen	OG4	5,08	100%	5,08						
Zuschlag	<b>Balkon</b>	OG4	<b>6,06</b>		6,06		25% vom NW/m <sup>2</sup>		0,26	2	73
Zubehör	<b>ER 1-31</b>	KG	<b>1,63</b>		1,63	0,30			0,30	1	1

<b>Whg-TOP 333</b>	<b>Mindestanteil:</b>	<b>74</b>	<b>von</b>	<b>14538</b>
--------------------	-----------------------	-----------	------------	--------------

<b>Whg-TOP 334</b>	<b>NFI.</b>		<b>67,34</b>		<b>67,34</b>	1,00	Z1(+10%), A10(-5%)	5,0%	1,05	71	
	VR	OG4	8,33	100%	8,33						
	WC	OG4	2,03	100%	2,03						
	Gang	OG4	2,05	100%	2,05						
	AR	OG4	1,68	100%	1,68						
	Bad	OG4	5,62	100%	5,62						
	Zimmer 1	OG4	10,64	100%	10,64						
	Zimmer 2	OG4	12,29	100%	12,29						
	Wohnen	OG4	19,62	100%	19,62						
	Kochen	OG4	5,08	100%	5,08						
Zuschlag	<b>Balkon</b>	OG4	<b>6,06</b>		6,06		25% vom NW/m <sup>2</sup>		0,26	2	73
Zubehör	<b>ER 1-32</b>	KG	<b>1,64</b>		1,64	0,30			0,30	1	1

<b>Whg-TOP 334</b>	<b>Mindestanteil:</b>	<b>74</b>	<b>von</b>	<b>14538</b>
--------------------	-----------------------	-----------	------------	--------------



<b>Whg-TOP 335</b>	<b>NFI.</b>		<b>67,61</b>		<b>67,61</b>	1,00	Z1(+10%), A10(-5%)	5,0%	1,05	71	
	VR	OG4	8,24	100%	8,24						
	WC	OG4	2,05	100%	2,05						
	Gang	OG4	2,10	100%	2,10						
	AR	OG4	1,68	100%	1,68						
	Bad	OG4	5,69	100%	5,69						
	Zimmer 1	OG4	10,47	100%	10,47						
	Zimmer 2	OG4	12,45	100%	12,45						
	Wohnen	OG4	19,83	100%	19,83						
	Kochen	OG4	5,10	100%	5,10						
Zuschlag	<b>Balkon</b>	OG4	<b>6,06</b>		6,06		25% vom NW/m <sup>2</sup>		0,26	2	73
Zubehör	<b>ER 1-33</b>	KG	<b>1,61</b>		1,61	0,30			0,30	1	1

<b>Whg-TOP 335</b>	<b>Mindestanteil:</b>	<b>74</b>	<b>von</b>	<b>14538</b>
--------------------	-----------------------	-----------	------------	--------------

<b>Whg-TOP 336</b>	<b>NFI.</b>		<b>70,43</b>		<b>70,43</b>	1,00	Z1(+10%), A10(-5%)	5,0%	1,05	74	
	VR	OG4	6,88	100%	6,88						
	WC	OG4	1,85	100%	1,85						
	Gang	OG4	1,92	100%	1,92						
	AR	OG4	2,15	100%	2,15						
	Bad	OG4	7,67	100%	7,67						
	Zimmer 1	OG4	11,18	100%	11,18						
	Zimmer 2	OG4	15,41	100%	15,41						
	Wohnen	OG4	17,09	100%	17,09						
	Kochen	OG4	6,28	100%	6,28						
Zuschlag	<b>Balkon</b>	OG4	<b>6,06</b>		6,06		25% vom NW/m <sup>2</sup>		0,26	2	76
Zubehör	<b>ER 1-34</b>	KG	<b>1,61</b>		1,61	0,30			0,30	1	1

<b>Whg-TOP 336</b>	<b>Mindestanteil:</b>	<b>77</b>	<b>von</b>	<b>14538</b>
--------------------	-----------------------	-----------	------------	--------------

## STIEGE 4

### Erdgeschoss

<b>Whg-TOP 401</b>	<b>NFI.</b>		<b>66,59</b>		<b>66,59</b>	1,00	A3(-5%)	-5,0%	0,95	63	
	VR	EG	5,95	100%	5,95						
	WC	EG	2,87	100%	2,87						
	Gang	EG	2,10	100%	2,10						
	AR	EG	1,14	100%	1,14						
	Bad	EG	4,66	100%	4,66						
	Zimmer 1	EG	12,39	100%	12,39						
	Zimmer 2	EG	11,00	100%	11,00						
	Wohnen	EG	19,08	100%	19,08						
	Kochen	EG	7,40	100%	7,40						
Zuschlag	<b>Terrasse</b>	EG	<b>17,14</b>		17,14		25% vom NW/m <sup>2</sup>		0,24	4	67
Zubehör	<b>Garten Top 401</b>	EG	<b>41,17</b>		41,17	0,10			0,10	4	
Zubehör	<b>ER 1-37</b>	KG	<b>1,61</b>		1,61	0,30			0,30	1	5

<b>Whg-TOP 401</b>	<b>Mindestanteil:</b>	<b>72</b>	<b>von</b>	<b>14538</b>
--------------------	-----------------------	-----------	------------	--------------



Whg-TOP 402	NFI.		87,39		77,52	1,00	A3(-5%)	-5,0%	0,95	74	
	VR	EG	8,42	100%	8,42						
	WC	EG	1,94	100%	1,94						
	Gang	EG	2,08	100%	2,08						
	AR	EG	1,69	100%	1,69						
	Bad	EG	5,86	100%	5,86						
	Zimmer 1	EG	10,62	100%	10,62						
	Zimmer 2	EG	12,39	100%	12,39						
	Wohnen	EG	19,59	100%	19,59						
	Kochen	EG	5,06	100%	5,06						
	Loggia	EG	19,74	50%	9,87					74	
Zubehör	Garten Top 402	EG	47,73		47,73	0,10			0,10	5	5

<b>Whg-TOP 402</b>	<b>Mindestanteil:</b>	<b>79</b>	<b>von</b>	<b>14538</b>
--------------------	-----------------------	-----------	------------	--------------

Whg-TOP 403	NFI.		90,21		90,21	1,00	A3(-5%), A19(-2%), Z6(+3%)	-4,0%	0,96	87	
	VR	EG	8,78	100%	8,78						
	Gang	EG	6,54	100%	6,54						
	Bad	EG	6,15	100%	6,15						
	Dusche/WC	EG	4,94	100%	4,94						
	AR	EG	1,12	100%	1,12						
	Zimmer 1	EG	11,00	100%	11,00						
	Zimmer 2	EG	13,65	100%	13,65						
	Zimmer 3	EG	11,55	100%	11,55						
	Wohnen	EG	19,08	100%	19,08						
	Kochen	EG	7,40	100%	7,40						
Zuschlag	Terrasse	EG	26,65		26,65		25% vom NW/m <sup>2</sup>		0,24	6	93
Zubehör	Garten Top 403	EG	88,38		88,38	0,10			0,10	9	
Zubehör	ER 1-35	KG	1,61		1,61	0,30			0,30	1	10

<b>Whg-TOP 403</b>	<b>Mindestanteil:</b>	<b>103</b>	<b>von</b>	<b>14538</b>
--------------------	-----------------------	------------	------------	--------------

Whg-TOP 404	NFI.		90,21		90,21	1,00	A3(-5%), A19(-2%), Z6(+3%)	-4,0%	0,96	87	
	VR	EG	8,78	100%	8,78						
	Gang	EG	6,54	100%	6,54						
	Bad	EG	6,15	100%	6,15						
	Dusche/WC	EG	4,94	100%	4,94						
	AR	EG	1,12	100%	1,12						
	Zimmer 1	EG	11,00	100%	11,00						
	Zimmer 2	EG	13,65	100%	13,65						
	Zimmer 3	EG	11,55	100%	11,55						
	Wohnen	EG	19,08	100%	19,08						
	Kochen	EG	7,40	100%	7,40						
Zuschlag	Terrasse	EG	26,65		26,65		25% vom NW/m <sup>2</sup>		0,24	6	93
Zubehör	Garten Top 404	EG	83,00		83,00	0,10			0,10	8	
Zubehör	ER 1-36	KG	1,61		1,61	0,30			0,30	1	9

<b>Whg-TOP 404</b>	<b>Mindestanteil:</b>	<b>102</b>	<b>von</b>	<b>14538</b>
--------------------	-----------------------	------------	------------	--------------



Whg-TOP 405	NFI.		87,37		77,50	1,00	A3(-5%)	-5,0%	0,95	74
	VR	EG	8,42	100%	8,42					
	WC	EG	1,94	100%	1,94					
	Gang	EG	2,08	100%	2,08					
	AR	EG	1,69	100%	1,69					
	Bad	EG	5,84	100%	5,84					
	Zimmer 1	EG	10,62	100%	10,62					
	Zimmer 2	EG	12,39	100%	12,39					
	Wohnen	EG	19,59	100%	19,59					
	Kochen	EG	5,06	100%	5,06					
	Loggia	EG	19,74	50%	9,87					74
Zubehör	Garten Top 405	EG	34,24		34,24	0,10			0,10	3

<b>Whg-TOP 405</b>	<b>Mindestanteil:</b>	<b>77</b>	<b>von</b>	<b>14538</b>
--------------------	-----------------------	-----------	------------	--------------

Whg-TOP 406	NFI.		66,59		66,59	1,00	A3(-5%)	-5,0%	0,95	63
	VR	EG	5,95	100%	5,95					
	WC	EG	2,87	100%	2,87					
	Gang	EG	2,10	100%	2,10					
	AR	EG	1,14	100%	1,14					
	Bad	EG	4,66	100%	4,66					
	Zimmer 1	EG	12,39	100%	12,39					
	Zimmer 2	EG	11,00	100%	11,00					
	Wohnen	EG	19,08	100%	19,08					
	Kochen	EG	7,40	100%	7,40					
Zuschlag	Terrasse	EG	17,14		17,14		25% vom NW/m <sup>2</sup>		0,24	4
Zubehör	Garten Top 406	EG	29,53		29,53	0,10			0,10	3

<b>Whg-TOP 406</b>	<b>Mindestanteil:</b>	<b>70</b>	<b>von</b>	<b>14538</b>
--------------------	-----------------------	-----------	------------	--------------

Whg-TOP 407	NFI.		90,21		90,21	1,00	A3(-5%), A19(-2%), Z6(+3%)	-4,0%	0,96	87
	VR	EG	8,78	100%	8,78					
	Gang	EG	6,54	100%	6,54					
	Bad	EG	6,15	100%	6,15					
	Dusche/WC	EG	4,94	100%	4,94					
	AR	EG	1,12	100%	1,12					
	Zimmer 1	EG	11,00	100%	11,00					
	Zimmer 2	EG	13,65	100%	13,65					
	Zimmer 3	EG	11,55	100%	11,55					
	Wohnen	EG	19,08	100%	19,08					
	Kochen	EG	7,40	100%	7,40					
Zuschlag	Terrasse	EG	26,70		26,70		25% vom NW/m <sup>2</sup>		0,24	6
Zubehör	Garten Top 407	EG	35,86		35,86	0,10			0,10	4
Zubehör	ER 4-10	KG	2,13		2,13	0,30			0,30	1

<b>Whg-TOP 407</b>	<b>Mindestanteil:</b>	<b>98</b>	<b>von</b>	<b>14538</b>
--------------------	-----------------------	-----------	------------	--------------



<b>Whg-TOP 408</b>	<b>NFI.</b>		<b>115,12</b>		<b>102,94</b>	1,00	A3(-5%), A19(-2%), Z6(+3%)	-4,0%	0,96	99
	VR	EG	8,78	100%	8,78					
	Gang	EG	6,54	100%	6,54					
	AR	EG	1,20	100%	1,20					
	Dusche/WC	EG	5,13	100%	5,13					
	Bad	EG	6,15	100%	6,15					
	Zimmer 1	EG	11,00	100%	11,00					
	Zimmer 2	EG	13,65	100%	13,65					
	Zimmer 3	EG	11,82	100%	11,82					
	Wohnen	EG	19,08	100%	19,08					
	Kochen	EG	7,40	100%	7,40					
	<b>Loggia</b>	EG	<b>24,37</b>	50%	12,19					99
Zubehör	<b>Garten Top 408</b>	EG	<b>36,18</b>		36,18	0,10			0,10	4
Zubehör	<b>ER 4-11</b>	KG	<b>2,18</b>		2,18	0,30			0,30	1

<b>Whg-TOP 408</b>	<b>Mindestanteil:</b>	<b>104</b>	<b>von</b>	<b>14538</b>
--------------------	-----------------------	------------	------------	--------------

<b>Whg-TOP 409</b>	<b>NFI.</b>		<b>115,12</b>		<b>102,94</b>	1,00	A3(-5%), A19(-2%), Z6(+3%)	-4,0%	0,96	99
	VR	EG	8,78	100%	8,78					
	Gang	EG	6,54	100%	6,54					
	AR	EG	1,20	100%	1,20					
	Dusche/WC	EG	5,13	100%	5,13					
	Bad	EG	6,15	100%	6,15					
	Zimmer 1	EG	11,00	100%	11,00					
	Zimmer 2	EG	13,65	100%	13,65					
	Zimmer 3	EG	11,82	100%	11,82					
	Wohnen	EG	19,08	100%	19,08					
	Kochen	EG	7,40	100%	7,40					
	<b>Loggia</b>	EG	<b>24,37</b>	50%	12,19					99
Zubehör	<b>Garten Top 409</b>	EG	<b>74,37</b>		74,37	0,10			0,10	7

<b>Whg-TOP 409</b>	<b>Mindestanteil:</b>	<b>106</b>	<b>von</b>	<b>14538</b>
--------------------	-----------------------	------------	------------	--------------

<b>Whg-TOP 410</b>	<b>NFI.</b>		<b>90,21</b>		<b>90,21</b>	1,00	A3(-5%), A19(-2%), Z6(+3%)	-4,0%	0,96	87
	VR	EG	8,78	100%	8,78					
	Gang	EG	6,54	100%	6,54					
	Bad	EG	6,15	100%	6,15					
	Dusche/WC	EG	4,94	100%	4,94					
	AR	EG	1,12	100%	1,12					
	Zimmer 1	EG	11,00	100%	11,00					
	Zimmer 2	EG	13,65	100%	13,65					
	Zimmer 3	EG	11,55	100%	11,55					
	Wohnen	EG	19,08	100%	19,08					
	Kochen	EG	7,40	100%	7,40					
Zuschlag	<b>Terrasse</b>	EG	<b>26,65</b>		26,65		25% vom NW/m <sup>2</sup>		0,24	6
Zubehör	<b>Garten Top 410</b>	EG	<b>74,37</b>		74,37	0,10			0,10	7

<b>Whg-TOP 410</b>	<b>Mindestanteil:</b>	<b>100</b>	<b>von</b>	<b>14538</b>
--------------------	-----------------------	------------	------------	--------------



**Obergeschoß 1**

<b>Whg-TOP 411</b>	<b>NFI.</b>		<b>83,86</b>		<b>75,23</b>	1,00		0,0%	1,00	75
	VR	OG1	5,95	100%	5,95					
	WC	OG1	2,87	100%	2,87					
	Gang	OG1	2,10	100%	2,10					
	AR	OG1	1,14	100%	1,14					
	Bad	OG1	4,66	100%	4,66					
	Zimmer 1	OG1	12,39	100%	12,39					
	Zimmer 2	OG1	11,00	100%	11,00					
	Wohnen	OG1	19,08	100%	19,08					
	Kochen	OG1	7,40	100%	7,40					
	<b>Loggia</b>	OG1	<b>17,27</b>	50%	8,64					75
<b>Whg-TOP 411</b>										
<b>Mindestanteil:</b>		<b>75</b>		<b>von 14538</b>						

<b>Whg-TOP 412</b>	<b>NFI.</b>		<b>87,62</b>		<b>77,64</b>	1,00		0,0%	1,00	78
	VR	OG1	8,42	100%	8,42					
	WC	OG1	1,94	100%	1,94					
	Gang	OG1	2,08	100%	2,08					
	AR	OG1	1,69	100%	1,69					
	Bad	OG1	5,86	100%	5,86					
	Zimmer 1	OG1	10,62	100%	10,62					
	Zimmer 2	OG1	12,39	100%	12,39					
	Wohnen	OG1	19,59	100%	19,59					
	Kochen	OG1	5,06	100%	5,06					
	<b>Loggia</b>	OG1	<b>19,97</b>	50%	9,99					78
Zubehör	<b>ER 1-38</b>	KG	<b>1,61</b>		1,61	0,30			0,30	1
<b>Whg-TOP 412</b>										
<b>Mindestanteil:</b>		<b>79</b>		<b>von 14538</b>						

<b>Whg-TOP 413</b>	<b>NFI.</b>		<b>90,21</b>		<b>90,21</b>	1,00	A19(-2%), Z6(+3%)	1,0%	1,01	91
	VR	OG1	8,78	100%	8,78					
	Gang	OG1	6,54	100%	6,54					
	Bad	OG1	6,15	100%	6,15					
	Dusche/WC	OG1	4,94	100%	4,94					
	AR	OG1	1,12	100%	1,12					
	Zimmer 1	OG1	11,00	100%	11,00					
	Zimmer 2	OG1	13,65	100%	13,65					
	Zimmer 3	OG1	11,55	100%	11,55					
	Wohnen	OG1	19,08	100%	19,08					
	Kochen	OG1	7,40	100%	7,40					
Zuschlag	<b>Balkon</b>	OG1	<b>26,91</b>		26,91		25% vom NW/m <sup>2</sup>		0,25	7
Zubehör	<b>ER 1-39</b>	KG	<b>1,60</b>		1,60	0,30			0,30	1
<b>Whg-TOP 413</b>										
<b>Mindestanteil:</b>		<b>99</b>		<b>von 14538</b>						





Whg-TOP 414	NFI.		90,56		90,56	1,00	A19(-2%), Z6(+3%)	1,0%	1,01	91	
	VR	OG1	8,78	100%	8,78						
	Gang	OG1	6,54	100%	6,54						
	Bad	OG1	6,15	100%	6,15						
	Dusche/WC	OG1	4,94	100%	4,94						
	AR	OG1	1,20	100%	1,20						
	Zimmer 1	OG1	11,00	100%	11,00						
	Zimmer 2	OG1	13,65	100%	13,65						
	Zimmer 3	OG1	11,82	100%	11,82						
	Wohnen	OG1	19,08	100%	19,08						
	Kochen	OG1	7,40	100%	7,40						
Zuschlag	<b>Balkon</b>	OG1	<b>26,91</b>		26,91		25% vom NW/m <sup>2</sup>		0,25	7	98
Zubehör	<b>ER 1-40</b>	KG	<b>1,60</b>		1,60	0,30			0,30	1	1

<b>Whg-TOP 414</b>	<b>Mindestanteil:</b>	<b>99</b>	<b>von</b>	<b>14538</b>
--------------------	-----------------------	-----------	------------	--------------

Whg-TOP 415	NFI.		57,12		50,89	1,00	A19(-2%)	-2,0%	0,98	50	
	Kochen	OG1	9,48	100%	9,48						
	Wohnen	OG1	16,38	100%	16,38						
	Bad	OG1	6,65	100%	6,65						
	Zimmer 1	OG1	12,15	100%	12,15						
	<b>Loggia</b>	OG1	<b>12,46</b>	50%	6,23					50	
Zubehör	<b>ER 1-41</b>	KG	<b>1,60</b>		1,60	0,30			0,30	1	1

<b>Whg-TOP 415</b>	<b>Mindestanteil:</b>	<b>51</b>	<b>von</b>	<b>14538</b>
--------------------	-----------------------	-----------	------------	--------------

Whg-TOP 416	NFI.		57,12		50,89	1,00	A19(-2%)	-2,0%	0,98	50	
	Kochen	OG1	9,48	100%	9,48						
	Wohnen	OG1	16,38	100%	16,38						
	Bad	OG1	6,65	100%	6,65						
	Zimmer 1	OG1	12,15	100%	12,15						
	<b>Loggia</b>	OG1	<b>12,46</b>	50%	6,23					50	
Zubehör	<b>ER 1-42</b>	KG	<b>1,60</b>		1,60	0,30			0,30	1	1

<b>Whg-TOP 416</b>	<b>Mindestanteil:</b>	<b>51</b>	<b>von</b>	<b>14538</b>
--------------------	-----------------------	-----------	------------	--------------

Whg-TOP 417	NFI.		56,64		50,65	1,00	A19(-2%)	-2,0%	0,98	50	
	Kochen	OG1	9,48	100%	9,48						
	Wohnen	OG1	16,38	100%	16,38						
	Bad	OG1	6,65	100%	6,65						
	Zimmer 1	OG1	12,15	100%	12,15						
	<b>Loggia</b>	OG1	<b>11,98</b>	50%	5,99					50	
Zubehör	<b>ER 1-43</b>	KG	<b>1,60</b>		1,60	0,30			0,30	1	1

<b>Whg-TOP 417</b>	<b>Mindestanteil:</b>	<b>51</b>	<b>von</b>	<b>14538</b>
--------------------	-----------------------	-----------	------------	--------------



<b>Whg-TOP 418</b>	<b>NFI.</b>		<b>67,65</b>		<b>67,65</b>	1,00		0,0%	1,00	68	
	VR	OG1	8,42	100%	8,42						
	WC	OG1	1,94	100%	1,94						
	Gang	OG1	2,08	100%	2,08						
	AR	OG1	1,69	100%	1,69						
	Bad	OG1	5,86	100%	5,86						
	Zimmer 1	OG1	10,62	100%	10,62						
	Zimmer 2	OG1	12,39	100%	12,39						
	Wohnen	OG1	19,59	100%	19,59						
	Kochen	OG1	5,06	100%	5,06						
Zuschlag	<b>Balkon</b>	OG1	<b>21,60</b>		21,60		25% vom NW/m <sup>2</sup>		0,25	5	73
Zubehör	<b>ER 4-19</b>	KG	<b>1,92</b>		1,92	0,30			0,30	1	1
<b>Whg-TOP 418</b>	<b>Mindestanteil:</b>		<b>74</b>	<b>von</b>	<b>14538</b>						

<b>Whg-TOP 419</b>	<b>NFI.</b>		<b>84,36</b>		<b>75,48</b>	1,00		0,0%	1,00	75	
	VR	OG1	5,95	100%	5,95						
	WC	OG1	2,87	100%	2,87						
	Zimmer 1	OG1	12,39	100%	12,39						
	Wohnen	OG1	19,08	100%	19,08						
	Kochen	OG1	7,40	100%	7,40						
	Gang	OG1	2,10	100%	2,10						
	Bad	OG1	4,66	100%	4,66						
	AR	OG1	1,14	100%	1,14						
	Zimmer 2	OG1	11,00	100%	11,00						
	<b>Loggia</b>	OG1	<b>17,77</b>	50%	8,89					75	
Zubehör	<b>ER 4-20</b>	KG	<b>1,92</b>		1,92	0,30			0,30	1	1
<b>Whg-TOP 419</b>	<b>Mindestanteil:</b>		<b>76</b>	<b>von</b>	<b>14538</b>						

<b>Whg-TOP 420</b>	<b>NFI.</b>		<b>44,66</b>		<b>44,66</b>	1,00	A19(-2%)	-2,0%	0,98	44	
	Kochen	OG1	9,48	100%	9,48						
	Wohnen	OG1	16,38	100%	16,38						
	Bad	OG1	6,65	100%	6,65						
	Zimmer 1	OG1	12,15	100%	12,15						
Zuschlag	<b>Balkon</b>	OG1	<b>12,02</b>		12,02		25% vom NW/m <sup>2</sup>		0,25	3	47
Zubehör	<b>ER 4-21</b>	KG	<b>1,96</b>		1,96	0,30			0,30	1	1
<b>Whg-TOP 420</b>	<b>Mindestanteil:</b>		<b>48</b>	<b>von</b>	<b>14538</b>						

<b>Whg-TOP 421</b>	<b>NFI.</b>		<b>44,66</b>		<b>44,66</b>	1,00	A19(-2%)	-2,0%	0,98	44	
	Kochen	OG1	9,48	100%	9,48						
	Wohnen	OG1	16,38	100%	16,38						
	Bad	OG1	6,65	100%	6,65						
	Zimmer 1	OG1	12,15	100%	12,15						
Zuschlag	<b>Balkon</b>	OG1	<b>12,02</b>		12,02		25% vom NW/m <sup>2</sup>		0,25	3	47
Zubehör	<b>ER 4-22</b>	KG	<b>2,13</b>		2,13	0,30			0,30	1	1
<b>Whg-TOP 421</b>	<b>Mindestanteil:</b>		<b>48</b>	<b>von</b>	<b>14538</b>						



<b>Whg-TOP 422</b>	<b>NFI.</b>		<b>84,36</b>		<b>75,48</b>	1,00		0,0%	1,00	75
	VR	OG1	5,95	100%	5,95					
	WC	OG1	2,87	100%	2,87					
	Zimmer 1	OG1	12,39	100%	12,39					
	Wohnen	OG1	19,08	100%	19,08					
	Kochen	OG1	7,40	100%	7,40					
	Gang	OG1	2,10	100%	2,10					
	Bad	OG1	4,66	100%	4,66					
	AR	OG1	1,14	100%	1,14					
	Zimmer 2	OG1	11,00	100%	11,00					
	<b>Loggia</b>	OG1	<b>17,77</b>	50%	8,89					75
Zubehör	<b>ER 4-23</b>	KG	<b>2,18</b>		2,18	0,30			0,30	1
<b>Whg-TOP 422</b>	<b>Mindestanteil:</b>		<b>76</b>	<b>von</b>	<b>14538</b>					

<b>Whg-TOP 423</b>	<b>NFI.</b>		<b>67,65</b>		<b>67,65</b>	1,00		0,0%	1,00	68
	VR	OG1	8,42	100%	8,42					
	WC	OG1	1,94	100%	1,94					
	Gang	OG1	2,08	100%	2,08					
	AR	OG1	1,69	100%	1,69					
	Bad	OG1	5,86	100%	5,86					
	Zimmer 1	OG1	10,62	100%	10,62					
	Zimmer 2	OG1	12,39	100%	12,39					
	Wohnen	OG1	19,59	100%	19,59					
	Kochen	OG1	5,06	100%	5,06					
Zuschlag	<b>Balkon</b>	OG1	<b>21,60</b>		21,60		25% vom NW/m <sup>2</sup>		0,25	5
Zubehör	<b>ER 4-24</b>	KG	<b>2,20</b>		2,20	0,30			0,30	1
<b>Whg-TOP 423</b>	<b>Mindestanteil:</b>		<b>74</b>	<b>von</b>	<b>14538</b>					

**Obergeschoß 2**

<b>Whg-TOP 424</b>	<b>NFI.</b>		<b>83,86</b>		<b>75,23</b>	1,00		0,0%	1,00	75
	VR	OG2	5,95	100%	5,95					
	WC	OG2	2,87	100%	2,87					
	Gang	OG2	2,10	100%	2,10					
	AR	OG2	1,14	100%	1,14					
	Bad	OG2	4,66	100%	4,66					
	Zimmer 1	OG2	12,39	100%	12,39					
	Zimmer 2	OG2	11,00	100%	11,00					
	Wohnen	OG2	19,08	100%	19,08					
	Kochen	OG2	7,40	100%	7,40					
	<b>Loggia</b>	OG2	<b>17,27</b>	50%	8,64					75
Zubehör	<b>ER 1-44</b>	KG	<b>1,64</b>		1,64	0,30			0,30	1
<b>Whg-TOP 424</b>	<b>Mindestanteil:</b>		<b>76</b>	<b>von</b>	<b>14538</b>					



Whg-TOP 425	NFI.		87,54		77,60	1,00		0,0%	1,00	78
	VR	OG2	8,42	100%	8,42					
	WC	OG2	1,94	100%	1,94					
	Gang	OG2	2,08	100%	2,08					
	AR	OG2	1,69	100%	1,69					
	Bad	OG2	5,86	100%	5,86					
	Zimmer 1	OG2	10,62	100%	10,62					
	Zimmer 2	OG2	12,39	100%	12,39					
	Wohnen	OG2	19,59	100%	19,59					
	Kochen	OG2	5,06	100%	5,06					
	Loggia	OG2	19,89	50%	9,95					78
Zubehör	ER 1-45	KG	1,57		1,57	0,30			0,30	1

<b>Whg-TOP 425</b>	<b>Mindestanteil:</b>	<b>79</b>	<b>von</b>	<b>14538</b>
--------------------	-----------------------	-----------	------------	--------------

Whg-TOP 426	NFI.		117,08		103,65	1,00	A19(-2%), Z6(+3%)	1,0%	1,01	105
	VR	OG2	8,78	100%	8,78					
	Gang	OG2	6,54	100%	6,54					
	Bad	OG2	6,15	100%	6,15					
	Dusche/WC	OG2	4,94	100%	4,94					
	AR	OG2	1,12	100%	1,12					
	Zimmer 1	OG2	11,00	100%	11,00					
	Zimmer 2	OG2	13,65	100%	13,65					
	Zimmer 3	OG2	11,55	100%	11,55					
	Wohnen	OG2	19,08	100%	19,08					
	Kochen	OG2	7,40	100%	7,40					
	Loggia	OG2	26,87	50%	13,44					105
Zubehör	ER 1-46	KG	1,58		1,58	0,30			0,30	1

<b>Whg-TOP 426</b>	<b>Mindestanteil:</b>	<b>106</b>	<b>von</b>	<b>14538</b>
--------------------	-----------------------	------------	------------	--------------

Whg-TOP 427	NFI.		117,41		103,99	1,00	A19(-2%), Z6(+3%)	1,0%	1,01	105
	VR	OG2	8,78	100%	8,78					
	Gang	OG2	6,54	100%	6,54					
	Bad	OG2	6,15	100%	6,15					
	Dusche/WC	OG2	4,94	100%	4,94					
	AR	OG2	1,20	100%	1,20					
	Zimmer 1	OG2	11,00	100%	11,00					
	Zimmer 2	OG2	13,65	100%	13,65					
	Zimmer 3	OG2	11,82	100%	11,82					
	Wohnen	OG2	19,08	100%	19,08					
	Kochen	OG2	7,40	100%	7,40					
	Loggia	OG2	26,85	50%	13,43					105
Zubehör	ER 1-47	KG	1,58		1,58	0,30			0,30	1

<b>Whg-TOP 427</b>	<b>Mindestanteil:</b>	<b>106</b>	<b>von</b>	<b>14538</b>
--------------------	-----------------------	------------	------------	--------------



<b>Whg-TOP 428</b>	<b>NFI.</b>		<b>57,12</b>		<b>50,89</b>	1,00	A19(-2%)	-2,0%	0,98	50
	Kochen	OG2	9,48	100%	9,48					
	Wohnen	OG2	16,38	100%	16,38					
	Bad	OG2	6,65	100%	6,65					
	Zimmer 1	OG2	12,15	100%	12,15					
	<b>Loggia</b>	OG2	<b>12,46</b>	50%	6,23					50
Zubehör	<b>ER 1-48</b>	KG	<b>1,58</b>		1,58	0,30			0,30	1 1

<b>Whg-TOP 428</b>	<b>Mindestanteil:</b>	<b>51</b>	<b>von</b>	<b>14538</b>
--------------------	-----------------------	-----------	------------	--------------

<b>Whg-TOP 429</b>	<b>NFI.</b>		<b>57,09</b>		<b>50,88</b>	1,00	A19(-2%)	-2,0%	0,98	50
	Kochen	OG2	9,48	100%	9,48					
	Wohnen	OG2	16,38	100%	16,38					
	Bad	OG2	6,65	100%	6,65					
	Zimmer 1	OG2	12,15	100%	12,15					
	<b>Loggia</b>	OG2	<b>12,43</b>	50%	6,22					50
Zubehör	<b>ER 1-49</b>	KG	<b>1,58</b>		1,58	0,30			0,30	1 1

<b>Whg-TOP 429</b>	<b>Mindestanteil:</b>	<b>51</b>	<b>von</b>	<b>14538</b>
--------------------	-----------------------	-----------	------------	--------------

<b>Whg-TOP 430</b>	<b>NFI.</b>		<b>56,64</b>		<b>50,65</b>	1,00	A19(-2%)	-2,0%	0,98	50
	Kochen	OG2	9,48	100%	9,48					
	Wohnen	OG2	16,38	100%	16,38					
	Bad	OG2	6,65	100%	6,65					
	Zimmer 1	OG2	12,15	100%	12,15					
	<b>Loggia</b>	OG2	<b>11,98</b>	50%	5,99					50
Zubehör	<b>ER 1-50</b>	KG	<b>1,56</b>		1,56	0,30			0,30	1 1

<b>Whg-TOP 430</b>	<b>Mindestanteil:</b>	<b>51</b>	<b>von</b>	<b>14538</b>
--------------------	-----------------------	-----------	------------	--------------

<b>Whg-TOP 431</b>	<b>NFI.</b>		<b>67,65</b>		<b>67,65</b>	1,00		0,0%	1,00	68
	VR	OG2	8,42	100%	8,42					
	WC	OG2	1,94	100%	1,94					
	Gang	OG2	2,08	100%	2,08					
	AR	OG2	1,69	100%	1,69					
	Bad	OG2	5,86	100%	5,86					
	Zimmer 1	OG2	10,62	100%	10,62					
	Zimmer 2	OG2	12,39	100%	12,39					
	Wohnen	OG2	19,59	100%	19,59					
	Kochen	OG2	5,06	100%	5,06					
Zuschlag	<b>Balkon</b>	OG2	<b>21,57</b>		21,57		25% vom NW/m <sup>2</sup>		0,25	5 73
Zubehör	<b>ER 4-25</b>	KG	<b>1,84</b>		1,84	0,30			0,30	1 1

<b>Whg-TOP 431</b>	<b>Mindestanteil:</b>	<b>74</b>	<b>von</b>	<b>14538</b>
--------------------	-----------------------	-----------	------------	--------------



<b>Whg-TOP 432</b>	<b>NFI.</b>		<b>84,31</b>		<b>75,45</b>	1,00		0,0%	1,00	75	
	VR	OG2	5,95	100%	5,95						
	WC	OG2	2,87	100%	2,87						
	Zimmer 1	OG2	12,39	100%	12,39						
	Wohnen	OG2	19,08	100%	19,08						
	Kochen	OG2	7,40	100%	7,40						
	Gang	OG2	2,10	100%	2,10						
	Bad	OG2	4,66	100%	4,66						
	AR	OG2	1,14	100%	1,14						
	Zimmer 2	OG2	11,00	100%	11,00						
	<b>Loggia</b>	OG2	<b>17,72</b>	50%	8,86					75	
Zubehör	<b>ER 4-26</b>	KG	<b>1,84</b>		1,84	0,30			0,30	1	1

<b>Whg-TOP 432</b>	<b>Mindestanteil:</b>	<b>76</b>	<b>von</b>	<b>14538</b>
--------------------	-----------------------	-----------	------------	--------------

<b>Whg-TOP 433</b>	<b>NFI.</b>		<b>56,64</b>		<b>50,65</b>	1,00	A19(-2%)	-2,0%	0,98	50	
	Kochen	OG2	9,48	100%	9,48						
	Wohnen	OG2	16,38	100%	16,38						
	Bad	OG2	6,65	100%	6,65						
	Zimmer 1	OG2	12,15	100%	12,15						
	<b>Loggia</b>	OG2	<b>11,98</b>	50%	5,99					50	
Zubehör	<b>ER 4-27</b>	KG	<b>2,01</b>		2,01	0,30			0,30	1	1

<b>Whg-TOP 433</b>	<b>Mindestanteil:</b>	<b>51</b>	<b>von</b>	<b>14538</b>
--------------------	-----------------------	-----------	------------	--------------

<b>Whg-TOP 434</b>	<b>NFI.</b>		<b>56,64</b>		<b>50,65</b>	1,00	A19(-2%)	-2,0%	0,98	50	
	Kochen	OG2	9,48	100%	9,48						
	Wohnen	OG2	16,38	100%	16,38						
	Bad	OG2	6,65	100%	6,65						
	Zimmer 1	OG2	12,15	100%	12,15						
	<b>Loggia</b>	OG2	<b>11,98</b>	50%	5,99					50	
Zubehör	<b>ER 4-28</b>	KG	<b>2,01</b>		2,01	0,30			0,30	1	1

<b>Whg-TOP 434</b>	<b>Mindestanteil:</b>	<b>51</b>	<b>von</b>	<b>14538</b>
--------------------	-----------------------	-----------	------------	--------------

<b>Whg-TOP 435</b>	<b>NFI.</b>		<b>84,34</b>		<b>75,47</b>	1,00		0,0%	1,00	75	
	VR	OG2	5,95	100%	5,95						
	WC	OG2	2,87	100%	2,87						
	Zimmer 1	OG2	12,39	100%	12,39						
	Wohnen	OG2	19,08	100%	19,08						
	Kochen	OG2	7,40	100%	7,40						
	Gang	OG2	2,10	100%	2,10						
	Bad	OG2	4,66	100%	4,66						
	AR	OG2	1,14	100%	1,14						
	Zimmer 2	OG2	11,00	100%	11,00						
	<b>Loggia</b>	OG2	<b>17,75</b>	50%	8,88					75	
Zubehör	<b>ER 4-29</b>	KG	<b>2,01</b>		2,01	0,30			0,30	1	1

<b>Whg-TOP 435</b>	<b>Mindestanteil:</b>	<b>76</b>	<b>von</b>	<b>14538</b>
--------------------	-----------------------	-----------	------------	--------------



<b>Whg-TOP 436</b>	<b>NFI.</b>		<b>67,65</b>		<b>67,65</b>	1,00		0,0%	1,00	68	
	VR	OG2	8,42	100%	8,42						
	WC	OG2	1,94	100%	1,94						
	Gang	OG2	2,08	100%	2,08						
	AR	OG2	1,69	100%	1,69						
	Bad	OG2	5,86	100%	5,86						
	Zimmer 1	OG2	10,62	100%	10,62						
	Zimmer 2	OG2	12,39	100%	12,39						
	Wohnen	OG2	19,59	100%	19,59						
	Kochen	OG2	5,06	100%	5,06						
Zuschlag	<b>Balkon</b>	OG2	<b>21,60</b>		21,60		25% vom NW/m <sup>2</sup>		0,25	5	73
Zubehör	<b>ER 4-30</b>	KG	<b>1,92</b>		1,92	0,30			0,30	1	1
<b>Whg-TOP 436</b>	<b>Mindestanteil:</b>		<b>74</b>	<b>von</b>	<b>14538</b>						

### Obergeschoß 3

<b>Whg-TOP 437</b>	<b>NFI.</b>		<b>83,86</b>		<b>75,23</b>	1,00	Z1(+10%), A10(-5%)	5,0%	1,05	79	
	VR	OG3	5,95	100%	5,95						
	WC	OG3	2,87	100%	2,87						
	Gang	OG3	2,10	100%	2,10						
	AR	OG3	1,14	100%	1,14						
	Bad	OG3	4,66	100%	4,66						
	Zimmer 1	OG3	12,39	100%	12,39						
	Zimmer 2	OG3	11,00	100%	11,00						
	Wohnen	OG3	19,08	100%	19,08						
	Kochen	OG3	7,40	100%	7,40						
	<b>Loggia</b>	OG3	<b>17,27</b>	50%	8,64					79	
Zubehör	<b>ER 4-12</b>	KG	<b>2,19</b>		2,19	0,30			0,30	1	1
<b>Whg-TOP 437</b>	<b>Mindestanteil:</b>		<b>80</b>	<b>von</b>	<b>14538</b>						

<b>Whg-TOP 438</b>	<b>NFI.</b>		<b>87,54</b>		<b>77,60</b>	1,00	Z1(+10%), A10(-5%)	5,0%	1,05	81	
	VR	OG3	8,42	100%	8,42						
	WC	OG3	1,94	100%	1,94						
	Gang	OG3	2,08	100%	2,08						
	AR	OG3	1,69	100%	1,69						
	Bad	OG3	5,86	100%	5,86						
	Zimmer 1	OG3	10,62	100%	10,62						
	Zimmer 2	OG3	12,39	100%	12,39						
	Wohnen	OG3	19,59	100%	19,59						
	Kochen	OG3	5,06	100%	5,06						
	<b>Loggia</b>	OG3	<b>19,89</b>	50%	9,95					81	
Zubehör	<b>ER 4-13</b>	KG	<b>1,87</b>		1,87	0,30			0,30	1	1
<b>Whg-TOP 438</b>	<b>Mindestanteil:</b>		<b>82</b>	<b>von</b>	<b>14538</b>						



Whg-TOP 439	NFI.		90,21		90,21	1,00	Z1(+10%), A10(-5%), A19(-2%), Z6(+3%)	6,0%	1,06	96	
	VR	OG3	8,78	100%	8,78						
	Gang	OG3	6,54	100%	6,54						
	Bad	OG3	6,15	100%	6,15						
	Dusche/WC	OG3	4,94	100%	4,94						
	AR	OG3	1,12	100%	1,12						
	Zimmer 1	OG3	11,00	100%	11,00						
	Zimmer 2	OG3	13,65	100%	13,65						
	Zimmer 3	OG3	11,55	100%	11,55						
	Wohnen	OG3	19,08	100%	19,08						
	Kochen	OG3	7,40	100%	7,40						
Zuschlag	<b>Balkon</b>	OG3	<b>26,91</b>		26,91		25% vom NW/m <sup>2</sup>		0,27	7	103
Zubehör	<b>ER 4-14</b>	KG	<b>1,87</b>		1,87	0,30			0,30	1	1

<b>Whg-TOP 439</b>	<b>Mindestanteil:</b>	<b>104</b>	<b>von</b>	<b>14538</b>
--------------------	-----------------------	------------	------------	--------------

Whg-TOP 440	NFI.		90,56		90,56	1,00	Z1(+10%), A10(-5%), A19(-2%), Z6(+3%)	6,0%	1,06	96	
	VR	OG3	8,78	100%	8,78						
	Gang	OG3	6,54	100%	6,54						
	Bad	OG3	6,15	100%	6,15						
	Dusche/WC	OG3	4,94	100%	4,94						
	AR	OG3	1,20	100%	1,20						
	Zimmer 1	OG3	11,00	100%	11,00						
	Zimmer 2	OG3	13,65	100%	13,65						
	Zimmer 3	OG3	11,82	100%	11,82						
	Wohnen	OG3	19,08	100%	19,08						
	Kochen	OG3	7,40	100%	7,40						
Zuschlag	<b>Balkon</b>	OG3	<b>26,83</b>		26,83		25% vom NW/m <sup>2</sup>		0,27	7	103
Zubehör	<b>ER 4-15</b>	KG	<b>2,01</b>		2,01	0,30			0,30	1	1

<b>Whg-TOP 440</b>	<b>Mindestanteil:</b>	<b>104</b>	<b>von</b>	<b>14538</b>
--------------------	-----------------------	------------	------------	--------------

Whg-TOP 441	NFI.		57,07		50,87	1,00	Z1(+10%), A10(-5%), A19(-2%)	3,0%	1,03	52	
	Kochen	OG3	9,48	100%	9,48						
	Wohnen	OG3	16,38	100%	16,38						
	Bad	OG3	6,65	100%	6,65						
	Zimmer 1	OG3	12,15	100%	12,15						
	<b>Loggia</b>	OG3	<b>12,41</b>	50%	6,21					52	
Zubehör	<b>ER 4-16</b>	KG	<b>2,01</b>		2,01	0,30			0,30	1	1

<b>Whg-TOP 441</b>	<b>Mindestanteil:</b>	<b>53</b>	<b>von</b>	<b>14538</b>
--------------------	-----------------------	-----------	------------	--------------

Whg-TOP 442	NFI.		57,12		50,89	1,00	Z1(+10%), A10(-5%), A19(-2%)	3,0%	1,03	52	
	Kochen	OG3	9,48	100%	9,48						
	Wohnen	OG3	16,38	100%	16,38						
	Bad	OG3	6,65	100%	6,65						
	Zimmer 1	OG3	12,15	100%	12,15						
	<b>Loggia</b>	OG3	<b>12,46</b>	50%	6,23					52	
Zubehör	<b>ER 4-17</b>	KG	<b>2,01</b>		2,01	0,30			0,30	1	1

<b>Whg-TOP 442</b>	<b>Mindestanteil:</b>	<b>53</b>	<b>von</b>	<b>14538</b>
--------------------	-----------------------	-----------	------------	--------------





<b>Whg-TOP 443</b>	<b>NFI.</b>		<b>56,64</b>		<b>50,65</b>	1,00	Z1(+10%), A10(-5%), A19(-2%)	3,0%	1,03	52
	Kochen	OG3	9,48	100%	9,48					
	Wohnen	OG3	16,38	100%	16,38					
	Bad	OG3	6,65	100%	6,65					
	Zimmer 1	OG3	12,15	100%	12,15					
	<b>Loggia</b>	OG3	<b>11,98</b>	50%	5,99					52
Zubehör	<b>ER 4-18</b>	KG	<b>1,92</b>		1,92	0,30			0,30	1 1

<b>Whg-TOP 443</b>	<b>Mindestanteil:</b>	<b>53 von 14538</b>
--------------------	-----------------------	---------------------

<b>Whg-TOP 444</b>	<b>NFI.</b>		<b>67,65</b>		<b>67,65</b>	1,00	Z1(+10%), A10(-5%)	5,0%	1,05	71
	VR	OG3	8,42	100%	8,42					
	WC	OG3	1,94	100%	1,94					
	Gang	OG3	2,08	100%	2,08					
	AR	OG3	1,69	100%	1,69					
	Bad	OG3	5,86	100%	5,86					
	Zimmer 1	OG3	10,62	100%	10,62					
	Zimmer 2	OG3	12,39	100%	12,39					
	Wohnen	OG3	19,59	100%	19,59					
	Kochen	OG3	5,06	100%	5,06					
Zuschlag	<b>Balkon</b>	OG3	<b>21,39</b>		21,39		25% vom NW/m <sup>2</sup>		0,26	6 77
Zubehör	<b>ER 4-31</b>	KG	<b>1,92</b>		1,92	0,30			0,30	1 1

<b>Whg-TOP 444</b>	<b>Mindestanteil:</b>	<b>78 von 14538</b>
--------------------	-----------------------	---------------------

<b>Whg-TOP 445</b>	<b>NFI.</b>		<b>84,20</b>		<b>75,40</b>	1,00	Z1(+10%), A10(-5%)	5,0%	1,05	79
	VR	OG3	5,95	100%	5,95					
	WC	OG3	2,87	100%	2,87					
	Zimmer 1	OG3	12,39	100%	12,39					
	Wohnen	OG3	19,08	100%	19,08					
	Kochen	OG3	7,40	100%	7,40					
	Gang	OG3	2,10	100%	2,10					
	Bad	OG3	4,66	100%	4,66					
	AR	OG3	1,14	100%	1,14					
	Zimmer 2	OG3	11,00	100%	11,00					
	<b>Loggia</b>	OG3	<b>17,61</b>	50%	8,81					79
Zubehör	<b>ER 4-32</b>	KG	<b>1,92</b>		1,92	0,30			0,30	1 1

<b>Whg-TOP 445</b>	<b>Mindestanteil:</b>	<b>80 von 14538</b>
--------------------	-----------------------	---------------------

<b>Whg-TOP 446</b>	<b>NFI.</b>		<b>44,66</b>		<b>44,66</b>	1,00	Z1(+10%), A10(-5%), A19(-2%)	3,0%	1,03	46
	Kochen	OG3	9,48	100%	9,48					
	Wohnen	OG3	16,38	100%	16,38					
	Bad	OG3	6,65	100%	6,65					
	Zimmer 1	OG3	12,15	100%	12,15					
Zuschlag	<b>Balkon</b>	OG3	<b>11,88</b>		11,88		25% vom NW/m <sup>2</sup>		0,26	3 49
Zubehör	<b>ER 4-33</b>	KG	<b>1,96</b>		1,96	0,30			0,30	1 1

<b>Whg-TOP 446</b>	<b>Mindestanteil:</b>	<b>50 von 14538</b>
--------------------	-----------------------	---------------------



<b>Whg-TOP 447</b>	<b>NFI.</b>		<b>44,66</b>		<b>44,66</b>	1,00	Z1(+10%), A10(-5%), A19(-2%)	3,0%	1,03	46	
	Kochen	OG3	9,48	100%	9,48						
	Wohnen	OG3	16,38	100%	16,38						
	Bad	OG3	6,65	100%	6,65						
	Zimmer 1	OG3	12,15	100%	12,15						
Zuschlag	<b>Balkon</b>	OG3	<b>11,88</b>		11,88		25% vom NW/m <sup>2</sup>		0,26	3	49
Zubehör	<b>ER 4-34</b>	KG	<b>2,13</b>		2,13	0,30			0,30	1	1

<b>Whg-TOP 447</b>	<b>Mindestanteil:</b>	<b>50</b>	<b>von</b>	<b>14538</b>
--------------------	-----------------------	-----------	------------	--------------

<b>Whg-TOP 448</b>	<b>NFI.</b>		<b>84,20</b>		<b>75,40</b>	1,00	Z1(+10%), A10(-5%)	5,0%	1,05	79	
	VR	OG3	5,95	100%	5,95						
	WC	OG3	2,87	100%	2,87						
	Zimmer 1	OG3	12,39	100%	12,39						
	Wohnen	OG3	19,08	100%	19,08						
	Kochen	OG3	7,40	100%	7,40						
	Gang	OG3	2,10	100%	2,10						
	Bad	OG3	4,66	100%	4,66						
	AR	OG3	1,14	100%	1,14						
	Zimmer 2	OG3	11,00	100%	11,00						
	<b>Loggia</b>	OG3	<b>17,61</b>	50%	8,81						79
Zubehör	<b>ER 4-35</b>	KG	<b>2,18</b>		2,18	0,30			0,30	1	1

<b>Whg-TOP 448</b>	<b>Mindestanteil:</b>	<b>80</b>	<b>von</b>	<b>14538</b>
--------------------	-----------------------	-----------	------------	--------------

<b>Whg-TOP 449</b>	<b>NFI.</b>		<b>67,65</b>		<b>67,65</b>	1,00	Z1(+10%), A10(-5%)	5,0%	1,05	71	
	VR	OG3	8,42	100%	8,42						
	WC	OG3	1,94	100%	1,94						
	Gang	OG3	2,08	100%	2,08						
	AR	OG3	1,69	100%	1,69						
	Bad	OG3	5,86	100%	5,86						
	Zimmer 1	OG3	10,62	100%	10,62						
	Zimmer 2	OG3	12,39	100%	12,39						
	Wohnen	OG3	19,59	100%	19,59						
	Kochen	OG3	5,06	100%	5,06						
Zuschlag	<b>Balkon</b>	OG3	<b>21,39</b>		21,39		25% vom NW/m <sup>2</sup>		0,26	6	77
Zubehör	<b>ER 4-36</b>	KG	<b>2,20</b>		2,20	0,30			0,30	1	1

<b>Whg-TOP 449</b>	<b>Mindestanteil:</b>	<b>78</b>	<b>von</b>	<b>14538</b>
--------------------	-----------------------	-----------	------------	--------------



**Mindestanteile:**

Stiege	Lage	TOP	Zubehör	NW ges.	Ges.
	KG	Stellplatz 1-001		9	14538
	KG	Stellplatz 1-002		9	14538
	KG	Stellplatz 1-003		9	14538
	KG	Stellplatz 1-004		9	14538
	KG	Stellplatz 1-005		9	14538
	KG	Stellplatz 1-006		9	14538
	KG	Stellplatz 1-007		9	14538
	KG	Stellplatz 1-008		9	14538
	KG	Stellplatz 1-009		9	14538
	KG	Stellplatz 1-010		9	14538
	KG	Stellplatz 1-011		9	14538
	KG	Stellplatz 1-012		9	14538
	KG	Stellplatz 1-013		9	14538
	KG	Stellplatz 1-014		9	14538
	KG	Stellplatz 1-015		9	14538
	KG	Stellplatz 1-016		9	14538
	KG	Stellplatz 1-017		9	14538
	KG	Stellplatz 1-018		9	14538
	KG	Stellplatz 1-019		9	14538
	KG	Stellplatz 1-020		9	14538
	KG	Stellplatz 1-021		9	14538
	KG	Stellplatz 1-022		9	14538
	KG	Stellplatz 1-023		9	14538
	KG	Stellplatz 1-024		9	14538
	KG	Stellplatz 1-025		9	14538
	KG	Stellplatz 1-026		9	14538
	KG	Stellplatz 1-027		9	14538
	KG	Stellplatz 1-028		9	14538
	KG	Stellplatz 1-029		9	14538
	KG	Stellplatz 1-030		9	14538
	KG	Stellplatz 1-031		9	14538
	KG	Stellplatz 1-032		9	14538
	KG	Stellplatz 1-033		9	14538
	KG	Stellplatz 1-034		9	14538
	KG	Stellplatz 1-035		9	14538
	KG	Stellplatz 1-036		9	14538
	KG	Stellplatz 1-037		9	14538
	KG	Stellplatz 1-038		9	14538
	KG	Stellplatz 1-039		9	14538
	KG	Stellplatz 1-040		9	14538



	KG	Stellplatz 1-041			9	14538
	KG	Stellplatz 1-042			9	14538
	KG	Stellplatz 1-043			9	14538
	KG	Stellplatz 1-044			9	14538
	KG	Stellplatz 1-045			9	14538
	KG	Stellplatz 1-046			9	14538
	KG	Stellplatz 1-047			9	14538
	KG	Stellplatz 1-048			9	14538
	KG	Stellplatz 1-049			9	14538
	KG	Stellplatz 1-050			9	14538
	KG	Stellplatz 1-051			9	14538
	KG	Stellplatz 1-052			9	14538
	KG	Stellplatz 1-053			9	14538
	KG	Stellplatz 1-054			9	14538
	KG	Stellplatz 1-055			9	14538
	KG	Stellplatz 1-056			9	14538
	KG	Stellplatz 1-057			9	14538
	KG	Stellplatz 1-058			9	14538
	KG	Stellplatz 1-059			9	14538
	KG	Stellplatz 1-060			9	14538
	KG	Stellplatz 1-061			9	14538
	KG	Stellplatz 1-062			9	14538
	KG	Stellplatz 1-063			9	14538
	KG	Stellplatz 1-064			9	14538
	KG	Stellplatz 1-065			9	14538
	KG	Stellplatz 1-068			9	14538
	KG	Stellplatz 1-069			9	14538
	KG	Stellplatz 1-070			9	14538
	KG	Stellplatz 1-071			9	14538
	KG	Stellplatz 1-072			9	14538
	KG	Stellplatz 1-073			9	14538
	KG	Stellplatz 1-074			9	14538
	KG	Stellplatz 1-075			9	14538
	KG	Stellplatz 1-076			9	14538
	KG	Stellplatz 1-077			9	14538
	KG	Stellplatz 1-078			9	14538
	KG	Stellplatz 1-079			9	14538
	KG	Stellplatz 1-080			9	14538
	KG	Stellplatz 1-081			9	14538
	KG	Stellplatz 1-082			9	14538
	KG	Stellplatz 1-083			9	14538
	KG	Stellplatz 1-084			11	14538
	KG	Stellplatz 1-085			11	14538
	KG	Stellplatz 1-086			11	14538



	KG	Stellplatz 1-087			11	14538
	KG	Stellplatz 1-088			9	14538
	KG	Stellplatz 1-089			9	14538
	KG	Stellplatz 1-090			9	14538
	KG	Stellplatz 1-091			9	14538
	KG	Stellplatz 1-092			9	14538
	KG	Stellplatz 1-093			9	14538
	KG	Stellplatz 1-094			9	14538
	KG	Stellplatz 1-095			9	14538
	KG	Stellplatz 1-096			9	14538
	KG	Stellplatz 1-097			9	14538
	KG	Stellplatz 1-098			9	14538
	KG	Stellplatz 1-099			9	14538
	KG	Stellplatz 1-100			9	14538
	KG	Stellplatz 1-101			9	14538
	KG	Stellplatz 1-102			9	14538
	KG	Stellplatz 1-103			9	14538
	KG	Stellplatz 1-104			9	14538
	KG	Stellplatz 1-105			11	14538
	KG	Stellplatz 1-106			11	14538
	KG	Stellplatz 1-107			9	14538
	KG	Stellplatz 1-108			9	14538
	KG	Stellplatz 1-109			11	14538
	KG	Stellplatz 1-110			11	14538
	KG	Stellplatz 1-111			9	14538
	KG	Stellplatz 1-112			9	14538
	KG	Stellplatz 1-113			9	14538
	KG	Stellplatz 1-114			9	14538
	KG	Stellplatz 1-115			9	14538
	KG	Stellplatz 1-116			9	14538
	KG	Stellplatz 1-117			9	14538
	KG	Stellplatz 1-118			9	14538
	KG	Stellplatz 1-119			9	14538
	KG	Stellplatz 1-120			9	14538
	KG	Stellplatz 1-121			9	14538
	KG	Stellplatz 1-122			9	14538
	KG	Stellplatz 1-123			9	14538
	KG	Stellplatz 1-124			9	14538
	KG	Stellplatz 1-125			9	14538
	KG	Stellplatz 1-126			10	14538
	KG	Stellplatz 1-127			9	14538
	KG	Stellplatz 1-128			9	14538
	KG	Stellplatz 1-129			9	14538
	KG	Stellplatz 1-130			9	14538



	KG	Stellplatz 1-131			11	14538
	KG	Stellplatz 1-132			11	14538
	KG	Stellplatz 1-133			9	14538
	KG	Stellplatz 1-134			9	14538
	KG	Stellplatz 1-135			9	14538
	KG	Stellplatz 1-136			9	14538
	KG	Stellplatz 1-137			9	14538
	KG	Stellplatz 1-138			9	14538
	KG	Stellplatz 1-139			9	14538
	KG	Stellplatz 1-140			9	14538
	KG	Stellplatz 1-141			9	14538
	KG	Stellplatz 1-142			9	14538
	KG	Stellplatz 1-143			9	14538
	KG	Stellplatz 1-144			9	14538
	KG	Stellplatz 1-145			9	14538
	KG	Stellplatz 1-146			9	14538
	KG	Stellplatz 1-147			9	14538
	KG	Stellplatz 1-148			9	14538
	KG	Stellplatz 1-149			9	14538
	KG	Stellplatz 1-150			9	14538
	KG	Stellplatz 1-151			9	14538
	KG	Stellplatz 1-152			9	14538
	KG	Stellplatz 1-153			9	14538
	KG	Stellplatz 1-154			9	14538
	KG	Stellplatz 1-155			9	14538
	KG	Stellplatz 1-156			9	14538
	KG	Stellplatz 1-157			9	14538
	KG	Stellplatz 1-158			9	14538
	KG	Stellplatz 1-159			9	14538
	KG	Stellplatz 1-160			11	14538
	KG	Stellplatz 1-161			11	14538
	KG	Stellplatz 1-162			9	14538
	KG	Stellplatz 1-163			9	14538
	KG	Stellplatz 1-164			9	14538
	KG	Stellplatz 1-165			9	14538
	KG	Stellplatz 1-166			9	14538
	KG	Stellplatz 1-167			9	14538
	KG	Stellplatz 1-168			9	14538
	KG	Stellplatz 1-169			9	14538
	KG	Stellplatz 1-170			9	14538
	KG	Stellplatz 1-171			9	14538
	KG	Stellplatz 1-172			9	14538
	KG	Stellplatz 1-173			9	14538
	KG	Stellplatz 1-174			9	14538



	KG	Stellplatz 1-175			9	14538
	KG	Stellplatz 1-176			9	14538
	KG	Stellplatz 1-177			9	14538
	KG	Stellplatz 1-178			9	14538
	KG	Stellplatz 1-179			9	14538
	KG	Stellplatz 1-180			9	14538
	KG	Stellplatz 1-181			9	14538
	KG	Stellplatz 1-182			9	14538
	KG	Stellplatz 1-183			9	14538
	EG	Stellplatz 1			6	14538
	EG	Stellplatz 2			6	14538
	EG	Stellplatz 3			6	14538
	EG	Stellplatz 4			6	14538
	EG	Stellplatz 5			6	14538
	EG	Stellplatz 6			6	14538
	EG	Stellplatz 7			6	14538
	EG	Stellplatz 8			6	14538
	EG	Stellplatz 9			6	14538
	EG	Stellplatz 10			6	14538
	EG	Stellplatz 11			6	14538
	EG	Stellplatz 12			6	14538
	EG	Stellplatz 13			6	14538
	EG	Stellplatz 14			6	14538
	EG	Stellplatz 15			6	14538
	EG	Stellplatz 16			6	14538
	EG	Stellplatz 17			6	14538
	EG	Stellplatz 18			6	14538
	EG	Stellplatz 21			9	14538
	EG	Stellplatz 22			6	14538
	EG	Stellplatz 23			6	14538
Stiege 1	EG	Geschäft-TOP G-1			328	14538
Stiege 1	KG	Whg-TOP 101		Garten Top 101	76	14538
Stiege 1	KG	Whg-TOP 102	ER 2-1	Garten Top 102	47	14538
Stiege 1	KG	Whg-TOP 103	ER 2-2	Garten Top 103	47	14538
Stiege 1	KG	Whg-TOP 104		Garten Top 104	81	14538
Stiege 1	OG1	Whg-TOP 105	ER 2-3		42	14538
Stiege 1	OG1	Whg-TOP 106	ER 2-4		67	14538
Stiege 1	OG1	Whg-TOP 107	ER 2-5		39	14538
Stiege 1	OG1	Whg-TOP 108	ER 2-6		72	14538
Stiege 1	OG1	Whg-TOP 109	ER 4-1		50	14538
Stiege 1	OG1	Whg-TOP 110	ER 2-8		45	14538
Stiege 1	OG1	Whg-TOP 111	ER 2-9		45	14538
Stiege 1	OG1	Whg-TOP 112	ER 2-10		44	14538
Stiege 1	OG1	Whg-TOP 113	ER 2-11		47	14538



Stiege 1	OG1	Whg-TOP 114	ER 2-12		75	14538
Stiege 1	OG1	Whg-TOP 115	ER 2-13		82	14538
Stiege 1	OG1	Whg-TOP 116	ER 2-14		47	14538
Stiege 1	OG1	Whg-TOP 117	ER 2-15		46	14538
Stiege 1	OG1	Whg-TOP 118	ER 2-16		47	14538
Stiege 1	OG1	Whg-TOP 119	ER 2-17		45	14538
Stiege 1	OG2	Whg-TOP 120	ER 2-18		44	14538
Stiege 1	OG2	Whg-TOP 121	ER 2-19		68	14538
Stiege 1	OG2	Whg-TOP 122	ER 2-20		39	14538
Stiege 1	OG2	Whg-TOP 123	ER 2-21		73	14538
Stiege 1	OG2	Whg-TOP 124	ER 4-2		51	14538
Stiege 1	OG2	Whg-TOP 125	ER 2-23		47	14538
Stiege 1	OG2	Whg-TOP 126	ER 2-24		47	14538
Stiege 1	OG2	Whg-TOP 127	ER 2-25		47	14538
Stiege 1	OG2	Whg-TOP 128	ER 2-26		47	14538
Stiege 1	OG2	Whg-TOP 129	ER 2-27		76	14538
Stiege 1	OG2	Whg-TOP 130	ER 2-28		84	14538
Stiege 1	OG2	Whg-TOP 131	ER 2-29		46	14538
Stiege 1	OG2	Whg-TOP 132	ER 2-30		47	14538
Stiege 1	OG2	Whg-TOP 133	ER 2-31		46	14538
Stiege 1	OG2	Whg-TOP 134	ER 2-32		47	14538
Stiege 1	OG3	Whg-TOP 135	ER 2-33		44	14538
Stiege 1	OG3	Whg-TOP 136	ER 2-34		68	14538
Stiege 1	OG3	Whg-TOP 137	ER 2-35		40	14538
Stiege 1	OG3	Whg-TOP 138	ER 2-36		74	14538
Stiege 1	OG3	Whg-TOP 139	ER 4-3		51	14538
Stiege 1	OG3	Whg-TOP 140	ER 2-38		47	14538
Stiege 1	OG3	Whg-TOP 141	ER 2-39		47	14538
Stiege 1	OG3	Whg-TOP 142	ER 2-40		47	14538
Stiege 1	OG3	Whg-TOP 143	ER 2-41		47	14538
Stiege 1	OG3	Whg-TOP 144	ER 2-42		76	14538
Stiege 1	OG3	Whg-TOP 145	ER 2-43		83	14538
Stiege 1	OG3	Whg-TOP 146	ER 2-44		47	14538
Stiege 1	OG3	Whg-TOP 147	ER 2-45		46	14538
Stiege 1	OG3	Whg-TOP 148	ER 2-46		47	14538
Stiege 1	OG3	Whg-TOP 149	ER 2-47		46	14538
Stiege 1	OG4	Whg-TOP 150	ER 2-48		44	14538
Stiege 1	OG4	Whg-TOP 151	ER 2-49		68	14538
Stiege 1	OG4	Whg-TOP 152	ER 2-50		40	14538
Stiege 1	OG4	Whg-TOP 153	ER 2-51		73	14538
Stiege 1	OG4	Whg-TOP 154	ER 4-4		51	14538
Stiege 1	OG4	Whg-TOP 155	ER 2-53		47	14538
Stiege 1	OG4	Whg-TOP 156	ER 2-54		47	14538
Stiege 1	OG4	Whg-TOP 157	ER 2-55		47	14538





Stiege 1	OG4	Whg-TOP 158	ER 2-56		47	14538
Stiege 1	OG4	Whg-TOP 159	ER 2-57		76	14538
Stiege 1	OG4	Whg-TOP 160	ER 2-58		88	14538
Stiege 1	OG4	Whg-TOP 161	ER 2-59		49	14538
Stiege 1	OG4	Whg-TOP 162	ER 2-60		49	14538
Stiege 1	OG4	Whg-TOP 163	ER 2-61		49	14538
Stiege 1	OG4	Whg-TOP 164	ER 2-62		49	14538
Stiege 1	OG5	Whg-TOP 165	ER 2-63	Terrasse 2 Top 165	48	14538
Stiege 1	OG5	Whg-TOP 166	ER 2-72	Terrasse 2 Top 166	79	14538
Stiege 1	OG5	Whg-TOP 167	ER 2-65		40	14538
Stiege 1	OG5	Whg-TOP 168	ER 2-68		73	14538
Stiege 1	OG5	Whg-TOP 169	ER 2-67		51	14538
Stiege 1	OG5	Whg-TOP 170	ER 2-66	Terrasse Top 170	58	14538
Stiege 1	OG5	Whg-TOP 171	ER 2-37	Terrasse Top 171	58	14538
Stiege 1	OG5	Whg-TOP 172	ER 2-70	Terrasse Top 172	58	14538
Stiege 1	OG5	Whg-TOP 173	ER 2-71	Terrasse Top 173	59	14538
Stiege 1	OG5	Whg-TOP 174	ER 2-64	Terrasse 2 Top 174	118	14538
Stiege 1	OG6	Whg-TOP 175	ER 2-7		46	14538
Stiege 1	OG6	Whg-TOP 176	ER 2-22		94	14538
Stiege 1	OG6	Whg-TOP 177	ER 2-69		96	14538
Stiege 1	OG6	Whg-TOP 178	ER 2-52		63	14538
Stiege 2	EG	Geschäft-TOP G-2			190	14538
Stiege 2	OG1	Whg-TOP 201	ER 3-1		33	14538
Stiege 2	OG1	Whg-TOP 202	ER 3-2		38	14538
Stiege 2	OG1	Whg-TOP 203	ER 3-3		37	14538
Stiege 2	OG1	Whg-TOP 204	ER 3-4		37	14538
Stiege 2	OG1	Whg-TOP 205	ER 3-5		70	14538
Stiege 2	OG1	Whg-TOP 206	ER 3-6		46	14538
Stiege 2	OG1	Whg-TOP 207	ER 3-7		75	14538
Stiege 2	OG2	Whg-TOP 208	ER 3-8		35	14538
Stiege 2	OG2	Whg-TOP 209	ER 3-9		38	14538
Stiege 2	OG2	Whg-TOP 210	ER 3-10		38	14538
Stiege 2	OG2	Whg-TOP 211	ER 3-11		37	14538
Stiege 2	OG2	Whg-TOP 212	ER 3-12		73	14538
Stiege 2	OG2	Whg-TOP 213	ER 3-13		48	14538
Stiege 2	OG2	Whg-TOP 214	ER 3-14		75	14538
Stiege 2	OG3	Whg-TOP 215	ER 3-15		35	14538
Stiege 2	OG3	Whg-TOP 216	ER 3-16		38	14538
Stiege 2	OG3	Whg-TOP 217	ER 3-17		38	14538
Stiege 2	OG3	Whg-TOP 218	ER 3-18		37	14538
Stiege 2	OG3	Whg-TOP 219	ER 3-19		73	14538
Stiege 2	OG3	Whg-TOP 220	ER 3-20		48	14538
Stiege 2	OG3	Whg-TOP 221	ER 3-21		75	14538
Stiege 2	OG4	Whg-TOP 222	ER 3-22		37	14538



Stiege 2	OG4	Whg-TOP 223	ER 3-23		40	14538
Stiege 2	OG4	Whg-TOP 224	ER 4-5		40	14538
Stiege 2	OG4	Whg-TOP 225	ER 4-6		39	14538
Stiege 2	OG4	Whg-TOP 226	ER 4-7		77	14538
Stiege 2	OG4	Whg-TOP 227	ER 4-8		51	14538
Stiege 2	OG4	Whg-TOP 228	ER 4-9		79	14538
Stiege 3	EG	Whg-TOP 301	ER 1-1	Garten Top 301	110	14538
Stiege 3	EG	Whg-TOP 302	ER 1-2	Garten Top 302	96	14538
Stiege 3	EG	Whg-TOP 303		Garten Top 303	68	14538
Stiege 3	EG	Whg-TOP 304		Garten Top 304	68	14538
Stiege 3	OG1	Whg-TOP 305	ER 1-3		70	14538
Stiege 3	OG1	Whg-TOP 306	ER 1-4		46	14538
Stiege 3	OG1	Whg-TOP 307	ER 1-5		97	14538
Stiege 3	OG1	Whg-TOP 308	ER 1-6		97	14538
Stiege 3	OG1	Whg-TOP 309	ER 1-7		70	14538
Stiege 3	OG1	Whg-TOP 310	ER 1-8		70	14538
Stiege 3	OG1	Whg-TOP 311	ER 1-9		66	14538
Stiege 3	OG1	Whg-TOP 312	ER 1-10		69	14538
Stiege 3	OG2	Whg-TOP 313	ER 1-11		70	14538
Stiege 3	OG2	Whg-TOP 314	ER 1-12		46	14538
Stiege 3	OG2	Whg-TOP 315	ER 1-13		97	14538
Stiege 3	OG2	Whg-TOP 316	ER 1-14		97	14538
Stiege 3	OG2	Whg-TOP 317	ER 1-15		70	14538
Stiege 3	OG2	Whg-TOP 318	ER 1-16		70	14538
Stiege 3	OG2	Whg-TOP 319	ER 1-17		71	14538
Stiege 3	OG2	Whg-TOP 320	ER 1-18		73	14538
Stiege 3	OG3	Whg-TOP 321	ER 1-19		70	14538
Stiege 3	OG3	Whg-TOP 322	ER 1-20		46	14538
Stiege 3	OG3	Whg-TOP 323	ER 1-21		97	14538
Stiege 3	OG3	Whg-TOP 324	ER 1-22		97	14538
Stiege 3	OG3	Whg-TOP 325	ER 1-23		70	14538
Stiege 3	OG3	Whg-TOP 326	ER 1-24		70	14538
Stiege 3	OG3	Whg-TOP 327	ER 1-25		71	14538
Stiege 3	OG3	Whg-TOP 328	ER 1-26		73	14538
Stiege 3	OG4	Whg-TOP 329	ER 1-27		74	14538
Stiege 3	OG4	Whg-TOP 330	ER 1-28		49	14538
Stiege 3	OG4	Whg-TOP 331	ER 1-29		103	14538
Stiege 3	OG4	Whg-TOP 332	ER 1-30		103	14538
Stiege 3	OG4	Whg-TOP 333	ER 1-31		74	14538
Stiege 3	OG4	Whg-TOP 334	ER 1-32		74	14538
Stiege 3	OG4	Whg-TOP 335	ER 1-33		74	14538
Stiege 3	OG4	Whg-TOP 336	ER 1-34		77	14538
Stiege 4	EG	Whg-TOP 401		Garten Top 401	72	14538
Stiege 4	EG	Whg-TOP 402		Garten Top 402	79	14538



Stiege 4	EG	Whg-TOP 403	ER 1-35	Garten Top 403	103	14538
Stiege 4	EG	Whg-TOP 404	ER 1-36	Garten Top 404	102	14538
Stiege 4	EG	Whg-TOP 405		Garten Top 405	77	14538
Stiege 4	EG	Whg-TOP 406		Garten Top 406	70	14538
Stiege 4	EG	Whg-TOP 407	ER 4-10	Garten Top 407	98	14538
Stiege 4	EG	Whg-TOP 408	ER 4-11	Garten Top 408	104	14538
Stiege 4	EG	Whg-TOP 409		Garten Top 409	106	14538
Stiege 4	EG	Whg-TOP 410		Garten Top 410	100	14538
Stiege 4	OG1	Whg-TOP 411	ER 1-37		75	14538
Stiege 4	OG1	Whg-TOP 412	ER 1-38		79	14538
Stiege 4	OG1	Whg-TOP 413	ER 1-39		99	14538
Stiege 4	OG1	Whg-TOP 414	ER 1-40		99	14538
Stiege 4	OG1	Whg-TOP 415	ER 1-41		51	14538
Stiege 4	OG1	Whg-TOP 416	ER 1-42		51	14538
Stiege 4	OG1	Whg-TOP 417	ER 1-43		51	14538
Stiege 4	OG1	Whg-TOP 418	ER 4-19		74	14538
Stiege 4	OG1	Whg-TOP 419	ER 4-20		76	14538
Stiege 4	OG1	Whg-TOP 420	ER 4-21		48	14538
Stiege 4	OG1	Whg-TOP 421	ER 4-22		48	14538
Stiege 4	OG1	Whg-TOP 422	ER 4-23		76	14538
Stiege 4	OG1	Whg-TOP 423	ER 4-24		74	14538
Stiege 4	OG2	Whg-TOP 424	ER 1-44		76	14538
Stiege 4	OG2	Whg-TOP 425	ER 1-45		79	14538
Stiege 4	OG2	Whg-TOP 426	ER 1-46		106	14538
Stiege 4	OG2	Whg-TOP 427	ER 1-47		106	14538
Stiege 4	OG2	Whg-TOP 428	ER 1-48		51	14538
Stiege 4	OG2	Whg-TOP 429	ER 1-49		51	14538
Stiege 4	OG2	Whg-TOP 430	ER 1-50		51	14538
Stiege 4	OG2	Whg-TOP 431	ER 4-25		74	14538
Stiege 4	OG2	Whg-TOP 432	ER 4-26		76	14538
Stiege 4	OG2	Whg-TOP 433	ER 4-27		51	14538
Stiege 4	OG2	Whg-TOP 434	ER 4-28		51	14538
Stiege 4	OG2	Whg-TOP 435	ER 4-29		76	14538
Stiege 4	OG2	Whg-TOP 436	ER 4-30		74	14538
Stiege 4	OG3	Whg-TOP 437	ER 4-12		80	14538
Stiege 4	OG3	Whg-TOP 438	ER 4-13		82	14538
Stiege 4	OG3	Whg-TOP 439	ER 4-14		104	14538
Stiege 4	OG3	Whg-TOP 440	ER 4-15		104	14538
Stiege 4	OG3	Whg-TOP 441	ER 4-16		53	14538
Stiege 4	OG3	Whg-TOP 442	ER 4-17		53	14538
Stiege 4	OG3	Whg-TOP 443	ER 4-18		53	14538
Stiege 4	OG3	Whg-TOP 444	ER 4-31		78	14538
Stiege 4	OG3	Whg-TOP 445	ER 4-32		80	14538
Stiege 4	OG3	Whg-TOP 446	ER 4-33		50	14538



Stiege 4	OG3	<b>Whg-TOP 447</b>	<b>ER 4-34</b>		<b>50</b>	<b>14538</b>
Stiege 4	OG3	<b>Whg-TOP 448</b>	<b>ER 4-35</b>		<b>80</b>	<b>14538</b>
Stiege 4	OG3	<b>Whg-TOP 449</b>	<b>ER 4-36</b>		<b>78</b>	<b>14538</b>
Gesamt					<b>14538</b>	<b>14538</b>

Wien, am 04.07.2022

Beilagen:

- korrigierte Stellplatznummerierung UG und Bezeichnung Kellerabteile (Beilage 1)
- Stellplatznummerierung EG (Beilage 2)
- Stellplatzmaße / Kotierungen (Beilage 3)
- Zuordnung Kellerabteile und m<sup>2</sup> der Kellerabteile (Beilage 4)
- Bezeichnung Gewerbeeinheiten neu inkl. Freiflächen (Beilage 5)
- Garten-/Terrassenbezeichnungen (Beilage 6)
- Top 177 Korrektur Fläche (Beilage 7)
- Top 178 Korrektur Balkon (Beilage 8)
- Top 174 Korrektur Fläche (Beilage 9)

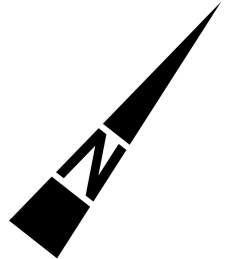

Projekt:

St. Pölten, Steingötterhof

Planinhalt:

BF1 - UG - Bezeichnung Kellerabteile

Plan-Nr.:

1876-Y-N-G-007

Datum:

10.09.2021

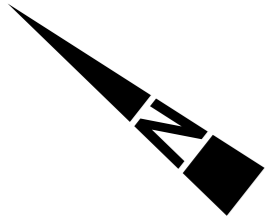

M 1:200

Projekt: St. Pölten, Steingötterhof

Planinhalt: BF1 - EG - Parkplatznummerierung

Plan-Nr.: 1876-Y-N-G-002

Datum: 10.09.2021

**BF 1 - Parkplätze**

07.09.2021	Tiefe [m]	Breite [m]	Fläche [m²]	Geschoß	Parkplatznummer									
<b>Typ 1</b>	5,0	2,5	<b>12,5</b>	UG	1-001	1-002	1-003	1-004	1-005	1-006	1-007	1-008	1-009	1-010
					1-011	1-012	1-013	1-014	1-015	1-016	1-017	1-018	1-019	1-020
					1-021	1-022	1-023	1-024	1-025	1-026	1-027	1-028	1-029	1-030
					1-031	1-032	1-033	1-034	1-035	1-036	1-037	1-038	1-039	1-040
					1-041	1-042	1-043	1-044	1-045	1-046	1-047	1-048	1-049	1-050
					1-051	1-052	1-053	1-054	1-055	1-056	1-057	1-058	1-059	1-060
					1-061	1-062	1-063	1-064	1-065	1-066	1-067	1-068	1-069	1-070
					1-071	1-072	1-073	1-074	1-075	1-076	1-077	1-078	1-079	1-080
					1-081	1-082	1-083	1-088	1-089	1-090	1-091	1-092	1-093	1-094
					1-095	1-096	1-097	1-098	1-099	1-100	1-101	1-102	1-103	1-104
					1-107	1-108	1-111	1-112	1-113	1-114	1-115	1-116	1-117	1-118
					1-119	1-120	1-121	1-122	1-123	1-124	1-125	1-127	1-128	1-129
					1-130	1-133	1-134	1-135	1-136	1-137	1-138	1-139	1-140	1-141
					1-142	1-143	1-144	1-145	1-146	1-147	1-148	1-149	1-150	1-151
					1-152	1-153	1-154	1-155	1-156	1-157	1-158	1-159	1-162	1-163
					1-164	1-165	1-166	1-167	1-168	1-169	1-170	1-171	1-172	1-173
					1-174	1-175	1-176	1-177	1-178	1-179	1-180	1-181	1-182	1-183
					EG	1	2	3	4	5	6	7	8	9
				11		12	13	14	15	16	17	18	19	20
22	23													
<b>Typ 2</b>	2,3	6,0	<b>13,8</b>	UG	1-126									
<b>Typ 3</b>	5,0	3,5	<b>17,5</b>	EG	21									
<b>Typ 4</b>	5,0	2,9	<b>14,5</b>	UG	1-084	1-085	1-086	1-087	1-105	1-106	1-109	1-110	1-131	1-132
					doppelter Beh-Parkplatz	1-160	1-161							

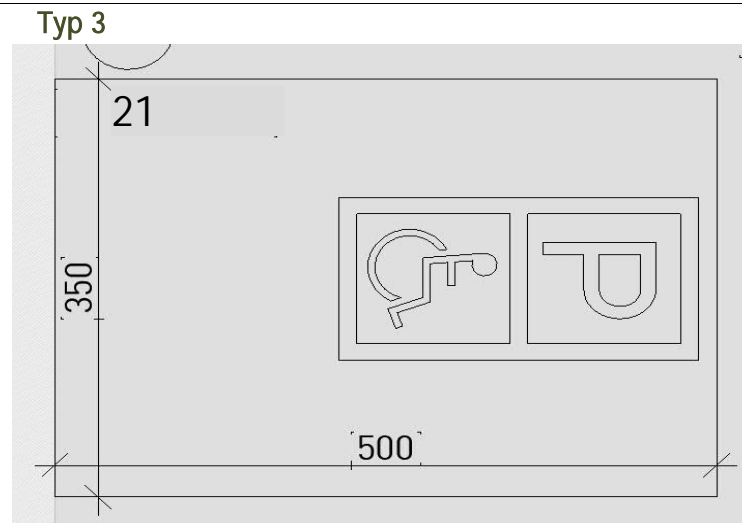
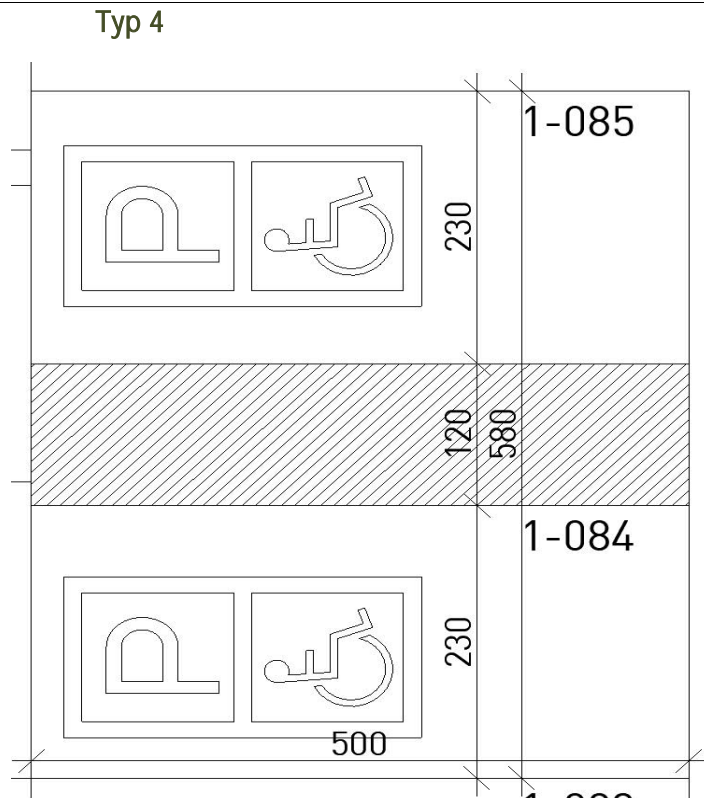
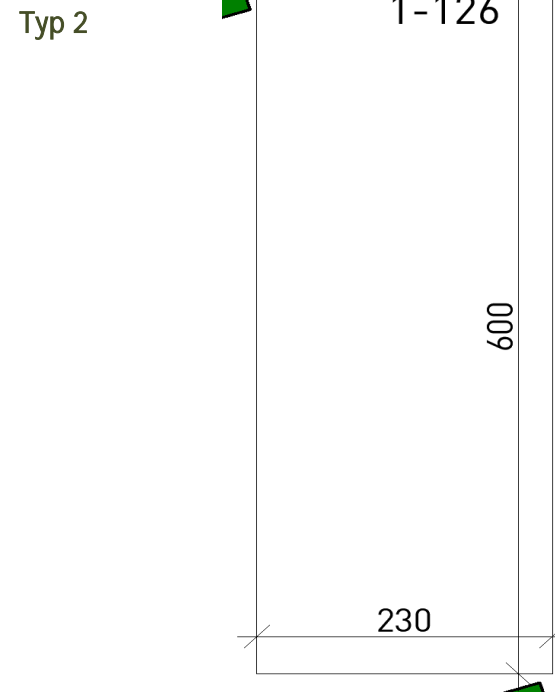
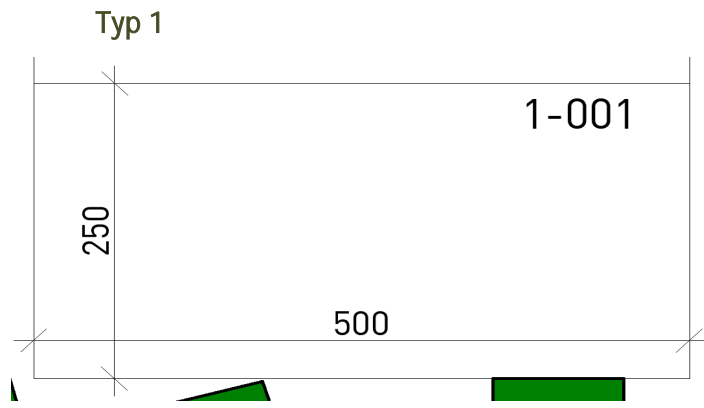



## ZUORDNUNG KELLERABTEILE

3107 St. Pölten, Dr. Wilhelm Steingötter-Straße - BAUFELD 1

Stiege	Geschoß	Top Nr.	Kellerabteil Nr.
Stiege 1	EG	S2.1	
Stiege 1	EG	101	
Stiege 1	EG	102	2-1
Stiege 1	EG	103	2-2
Stiege 1	EG	104	
Stiege 1	1.OG	105	2-3
Stiege 1	1.OG	106	2-4
Stiege 1	1.OG	107	2-5
Stiege 1	1.OG	108	2-6
Stiege 1	1.OG	109	4-1
Stiege 1	1.OG	110	2-8
Stiege 1	1.OG	111	2-9
Stiege 1	1.OG	112	2-10
Stiege 1	1.OG	113	2-11
Stiege 1	1.OG	114	2-12
Stiege 1	1.OG	115	2-13
Stiege 1	1.OG	116	2-14
Stiege 1	1.OG	117	2-15
Stiege 1	1.OG	118	2-16
Stiege 1	1.OG	119	2-17
Stiege 1	2.OG	120	2-18
Stiege 1	2.OG	121	2-19
Stiege 1	2.OG	122	2-20
Stiege 1	2.OG	123	2-21
Stiege 1	2.OG	124	4-2
Stiege 1	2.OG	125	2-23
Stiege 1	2.OG	126	2-24
Stiege 1	2.OG	127	2-25
Stiege 1	2.OG	128	2-26
Stiege 1	2.OG	129	2-27
Stiege 1	2.OG	130	2-28
Stiege 1	2.OG	131	2-29
Stiege 1	2.OG	132	2-30
Stiege 1	2.OG	133	2-31
Stiege 1	2.OG	134	2-32
Stiege 1	3.OG	135	2-33
Stiege 1	3.OG	136	2-34
Stiege 1	3.OG	137	2-35
Stiege 1	3.OG	138	2-36
Stiege 1	3.OG	139	4-3
Stiege 1	3.OG	140	2-38
Stiege 1	3.OG	141	2-39
Stiege 1	3.OG	142	2-40
Stiege 1	3.OG	143	2-41
Stiege 1	3.OG	144	2-42
Stiege 1	3.OG	145	2-43
Stiege 1	3.OG	146	2-44
Stiege 1	3.OG	147	2-45
Stiege 1	3.OG	148	2-46
Stiege 1	3.OG	149	2-47
Stiege 1	4.OG	150	2-48

## ZUORDNUNG KELLERABTEILE

3107 St. Pölten, Dr. Wilhelm Steingötter-Straße - BAUFELD 1

Stiege 1	4.OG	151	2-49
Stiege 1	4.OG	152	2-50
Stiege 1	4.OG	153	2-51
Stiege 1	4.OG	154	4-4
Stiege 1	4.OG	155	2-53
Stiege 1	4.OG	156	2-54
Stiege 1	4.OG	157	2-55
Stiege 1	4.OG	158	2-56
Stiege 1	4.OG	159	2-57
Stiege 1	4.OG	160	2-58
Stiege 1	4.OG	161	2-59
Stiege 1	4.OG	162	2-60
Stiege 1	4.OG	163	2-61
Stiege 1	4.OG	164	2-62
Stiege 1	5.OG	165	2-63
Stiege 1	5.OG	166	2-64
Stiege 1	5.OG	167	2-65
Stiege 1	5.OG	168	2-68
Stiege 1	5.OG	169	2-67
Stiege 1	5.OG	170	2-66
Stiege 1	5.OG	171	2-37
Stiege 1	5.OG	172	2-70
Stiege 1	5.OG	173	2-71
Stiege 1	5.OG	174	2-72
Stiege 1	6.OG	175	2-7
Stiege 1	6.OG	176	2-22
Stiege 1	6.OG	177	2-69
Stiege 1	6.OG	178	2-52
<b>Summe Einheiten STG 1</b>		<b>79</b>	<b>76</b>

## ZUORDNUNG KELLERABTEILE

3107 St. Pölten, Dr. Wilhelm Steingötter-Straße - BAUFELD 1

Stiege	Geschoß	Top Nr.	Kellerabteil Nr.
Stiege 2	EG	U1.1	
Stiege 2	1.OG	201	3-1
Stiege 2	1.OG	202	3-2
Stiege 2	1.OG	203	3-3
Stiege 2	1.OG	204	3-4
Stiege 2	1.OG	205	3-5
Stiege 2	1.OG	206	3-6
Stiege 2	1.OG	207	3-7
Stiege 2	2.OG	208	3-8
Stiege 2	2.OG	209	3-9
Stiege 2	2.OG	210	3-10
Stiege 2	2.OG	211	3-11
Stiege 2	2.OG	212	3-12
Stiege 2	2.OG	213	3-13
Stiege 2	2.OG	214	3-14
Stiege 2	3.OG	215	3-15
Stiege 2	3.OG	216	3-16
Stiege 2	3.OG	217	3-17
Stiege 2	3.OG	218	3-18
Stiege 2	3.OG	219	3-19
Stiege 2	3.OG	220	3-20
Stiege 2	3.OG	221	3-21
Stiege 2	4.OG	222	3-22
Stiege 2	4.OG	223	3-23
Stiege 2	4.OG	224	4-5
Stiege 2	4.OG	225	4-6
Stiege 2	4.OG	226	4-7
Stiege 2	4.OG	227	4-8
Stiege 2	4.OG	228	4-9
<b>Summe Einheiten STG 2</b>		<b>29</b>	<b>28</b>

Stiege	Geschoß	Top Nr.	Kellerabteil Nr.
Stiege 3	EG	301	1-1
Stiege 3	EG	302	1-2
Stiege 3	EG	303	
Stiege 3	EG	304	
Stiege 3	1.OG	305	1-3
Stiege 3	1.OG	306	1-4
Stiege 3	1.OG	307	1-5
Stiege 3	1.OG	308	1-6
Stiege 3	1.OG	309	1-7
Stiege 3	1.OG	310	1-8
Stiege 3	1.OG	311	1-9
Stiege 3	1.OG	312	1-10
Stiege 3	2.OG	313	1-11
Stiege 3	2.OG	314	1-12
Stiege 3	2.OG	315	1-13
Stiege 3	2.OG	316	1-14
Stiege 3	2.OG	317	1-15
Stiege 3	2.OG	318	1-16
Stiege 3	2.OG	319	1-17

## ZUORDNUNG KELLERABTEILE

3107 St. Pölten, Dr. Wilhelm Steingötter-Straße - BAUFELD 1

Stiege 3	2.OG	320	1-18
Stiege 3	3.OG	321	1-19
Stiege 3	3.OG	322	1-20
Stiege 3	3.OG	323	1-21
Stiege 3	3.OG	324	1-22
Stiege 3	3.OG	325	1-23
Stiege 3	3.OG	326	1-24
Stiege 3	3.OG	327	1-25
Stiege 3	3.OG	328	1-26
Stiege 3	4.OG	329	1-27
Stiege 3	4.OG	330	1-28
Stiege 3	4.OG	331	1-29
Stiege 3	4.OG	332	1-30
Stiege 3	4.OG	333	1-31
Stiege 3	4.OG	334	1-32
Stiege 3	4.OG	335	1-33
Stiege 3	4.OG	336	1-34
<b>Summe Einheiten STG 3</b>		<b>36</b>	<b>34</b>

Stiege	Geschoß	Top Nr.	Kellerabteil Nr.
Stiege 4	EG	401	
Stiege 4	EG	402	
Stiege 4	EG	403	1-35
Stiege 4	EG	404	1-36
Stiege 4	EG	405	
Stiege 4	EG	406	
Stiege 4	EG	407	4-10
Stiege 4	EG	408	4-11
Stiege 4	EG	409	
Stiege 4	EG	410	
Stiege 4	1.OG	411	1-37
Stiege 4	1.OG	412	1-38
Stiege 4	1.OG	413	1-39
Stiege 4	1.OG	414	1-40
Stiege 4	1.OG	415	1-41
Stiege 4	1.OG	416	1-42
Stiege 4	1.OG	417	1-43
Stiege 4	1.OG	418	4-19
Stiege 4	1.OG	419	4-20
Stiege 4	1.OG	420	4-21
Stiege 4	1.OG	421	4-22
Stiege 4	1.OG	422	4-23
Stiege 4	1.OG	423	4-24
Stiege 4	2.OG	424	1-44
Stiege 4	2.OG	425	1-45
Stiege 4	2.OG	426	1-46
Stiege 4	2.OG	427	1-47
Stiege 4	2.OG	428	1-48
Stiege 4	2.OG	429	1-49
Stiege 4	2.OG	430	1-50
Stiege 4	2.OG	431	4-25
Stiege 4	2.OG	432	4-26
Stiege 4	2.OG	433	4-27

## ZUORDNUNG KELLERABTEILE

3107 St. Pölten, Dr. Wilhelm Steingötter-Straße - BAUFELD 1

Stiege 4	2.OG	434	4-28
Stiege 4	2.OG	435	4-29
Stiege 4	2.OG	436	4-30
Stiege 4	3.OG	437	4-12
Stiege 4	3.OG	438	4-13
Stiege 4	3.OG	439	4-14
Stiege 4	3.OG	440	4-15
Stiege 4	3.OG	441	4-16
Stiege 4	3.OG	442	4-17
Stiege 4	3.OG	443	4-18
Stiege 4	3.OG	444	4-31
Stiege 4	3.OG	445	4-32
Stiege 4	3.OG	446	4-33
Stiege 4	3.OG	447	4-34
Stiege 4	3.OG	448	4-35
Stiege 4	3.OG	449	4-36
<b>Summe Einheiten STG 4</b>		<b>49</b>	<b>43</b>

Tops

Kellerabteile

<b>Summe Einheiten STG 1-4</b>	<b>193</b>	<b>181</b>
--------------------------------	------------	------------

Topographie - Berechnung der Grundflächen nach B ÖNORM 1800 (Angabe in m²)

10.09.2021

WOHNHAUSANLAGE DR.W. STEINGOTTERSTRASSE 25\_ST.POLTEN

Baufeld 1: Stiege 1 (Stadthaus 2), Stiege 2 (Urban Living 1), Stiege 3 (Stadthaus 1), Stiege 4 (Parkvilla 1)

TOP	TOP-Kategorie				Widmung	Fläche [m²]	NF [m²]	TF [m²]	VF [m²]	Gewerbe [m²]	Bodenbelag
	A	B	C	D							
<b>Untergeschoß BAUFELD 1</b>											
					Garage BF1.1	3.533,70	3.533,70				Beschichtung
					Garage BF1.2	1.231,58	1.231,58				Beschichtung
					Versickerung BF1.02	395,07		395,07			-
					Zuluft BF1.1	2,98		2,98			-
					Zuluft BF1.2	3,26		3,26			-
					Zuluft BF1.3	3,26		3,26			-
					Zuluft BF1.4	3,87		3,87			-
					Zuluft BF1.5	0,92		0,92			-
					Zuluft BF1.6	2,79		2,79			-
					Zuluft BF1.7	1,21		1,21			-
					Zuluft BF1.8	1,80		1,80			-
					Zuluft BF1.9	2,88		2,88			-
					Zuluft BF1.10	5,47		5,47			-
					Stiegenhaus S2	27,30			27,30		Feinsteinzeug
					Aufzug S2	2,88			2,88		-
					Schleuse S2	39,72			39,72		Beschichtung
					E-Raum S2	19,19		19,19			Beschichtung
					Technik/Heizung S2	45,53		45,53			Beschichtung
					<b>Keller S2</b>	<b>88,05</b>			<b>88,05</b>		<b>Beschichtung</b>
					Wasseranschluß BF1	5,07		5,07			Beschichtung
					FM-S2	4,82	4,82				Beschichtung
					2-1	1,81	1,81				Beschichtung
					2-2	1,81	1,81				Beschichtung
					2-3	1,81	1,81				Beschichtung
					2-4	1,81	1,81				Beschichtung
					2-5	1,81	1,81				Beschichtung
					2-6	1,82	1,82				Beschichtung
					2-7	2,29	2,29				Beschichtung
					2-8	1,75	1,75				Beschichtung
					2-9	1,76	1,76				Beschichtung
					2-10	1,77	1,77				Beschichtung
					2-11	1,77	1,77				Beschichtung
					2-12	1,78	1,78				Beschichtung
					2-13	1,80	1,80				Beschichtung
					2-14	1,62	1,62				Beschichtung
					2-15	1,62	1,62				Beschichtung
					2-16	1,62	1,62				Beschichtung
					2-17	1,62	1,62				Beschichtung
					2-18	1,62	1,62				Beschichtung
					2-19	1,62	1,62				Beschichtung
					2-20	1,67	1,67				Beschichtung
					2-21	1,61	1,61				Beschichtung
					2-22	1,62	1,62				Beschichtung
					2-23	1,62	1,62				Beschichtung
					2-24	1,62	1,62				Beschichtung
					2-25	1,62	1,62				Beschichtung
					2-26	1,62	1,62				Beschichtung
					2-27	1,75	1,75				Beschichtung
					2-28	1,65	1,65				Beschichtung
					2-29	1,65	1,65				Beschichtung

TOP	TOP-Kategorie				Widmung	Fläche [m²]	NF [m²]	TF [m²]	VF [m²]	Gewerbe [m²]	Bodenbelag
	A	B	C	D							
					2-30	1,65	1,65				Beschichtung
					2-31	1,71	1,71				Beschichtung
					2-32	1,81	1,81				Beschichtung
					2-33	1,96	1,96				Beschichtung
					2-34	1,97	1,97				Beschichtung
					2-35	2,01	2,01				Beschichtung
					2-36	1,81	1,81				Beschichtung
					2-37	1,81	1,81				Beschichtung
					2-38	1,81	1,81				Beschichtung
					2-39	1,81	1,81				Beschichtung
					2-40	1,81	1,81				Beschichtung
					2-41	1,81	1,81				Beschichtung
					2-42	1,81	1,81				Beschichtung
					2-43	1,81	1,81				Beschichtung
					2-44	1,95	1,95				Beschichtung
					2-45	1,94	1,94				Beschichtung
					2-46	1,68	1,68				Beschichtung
					2-47	1,68	1,68				Beschichtung
					2-48	1,68	1,68				Beschichtung
					2-49	1,68	1,68				Beschichtung
					2-50	1,71	1,71				Beschichtung
					2-51	1,96	1,96				Beschichtung
					2-52	1,94	1,94				Beschichtung
					2-53	1,94	1,94				Beschichtung
					2-54	1,94	1,94				Beschichtung
					2-55	1,94	1,94				Beschichtung
					2-56	1,96	1,96				Beschichtung
					2-57	1,65	1,65				Beschichtung
					2-58	1,68	1,68				Beschichtung
					2-59	1,68	1,68				Beschichtung
					2-60	1,68	1,68				Beschichtung
					2-61	1,68	1,68				Beschichtung
					2-62	1,94	1,94				Beschichtung
					2-63	1,95	1,95				Beschichtung
					2-64	4,59	4,59				Beschichtung
					2-65	2,26	2,26				Beschichtung
					2-66	2,29	2,29				Beschichtung
					2-67	2,02	2,02				Beschichtung
					2-68	3,65	3,65				Beschichtung
					2-69	3,63	3,63				Beschichtung
					2-70	2,19	2,19				Beschichtung
					2-71	2,19	2,19				Beschichtung
					2-72	2,19	2,19				Beschichtung
					Stiegenhaus U1	32,32			32,32		Feinsteinzeug
					Aufzug U1	4,13			4,13		-
					Schleuse U1.1	8,43			8,43		Beschichtung
					E-Raum U1	10,05		10,05			Beschichtung
					Technik/Heizung U1	19,28		19,28			Beschichtung
					Fahrradraum U1.2	16,10					Beschichtung
					Keller U1	32,02			32,02		Beschichtung
					FM U1	3,41	3,41				Beschichtung
					3-1	1,93	1,93				Beschichtung
					3-2	1,92	1,92				Beschichtung
					3-3	1,92	1,92				Beschichtung
					3-4	1,92	1,92				Beschichtung
					3-5	1,93	1,93				Beschichtung
					3-6	1,92	1,92				Beschichtung
					3-7	1,92	1,92				Beschichtung
					3-8	1,92	1,92				Beschichtung
					3-9	1,32	1,32				Beschichtung

TOP	TOP-Kategorie				Widmung	Fläche [m²]	NF [m²]	TF [m²]	VF [m²]	Gewerbe [m²]	Bodenbelag
	A	B	C	D							
					3-10	1,32	1,32				Beschichtung
					3-11	1,32	1,32				Beschichtung
					3-12	1,32	1,32				Beschichtung
					3-13	1,35	1,35				Beschichtung
					3-14	1,32	1,32				Beschichtung
					3-15	1,32	1,32				Beschichtung
					3-16	1,32	1,32				Beschichtung
					3-17	1,32	1,32				Beschichtung
					3-18	1,35	1,35				Beschichtung
					3-19	2,09	2,09				Beschichtung
					3-20	2,09	2,09				Beschichtung
					3-21	2,09	2,09				Beschichtung
					3-22	2,09	2,09				Beschichtung
					3-23	2,09	2,09				Beschichtung
					Keller	34,95			34,95		Beschichtung
					4-1	1,78	1,78				Beschichtung
					4-2	1,78	1,78				Beschichtung
					4-3	2,01	2,01				Beschichtung
					4-4	2,01	2,01				Beschichtung
					4-5	2,01	2,01				Beschichtung
					4-6	1,92	1,92				Beschichtung
					4-7	1,92	1,92				Beschichtung
					4-8	1,92	1,92				Beschichtung
					4-9	1,87	1,87				Beschichtung
					4-10	2,13	2,13				Beschichtung
					4-11	2,18	2,18				Beschichtung
					4-12	2,19	2,19				Beschichtung
					4-13	1,87	1,87				Beschichtung
					4-14	1,87	1,87				Beschichtung
					4-15	2,01	2,01				Beschichtung
					4-16	2,01	2,01				Beschichtung
					4-17	2,01	2,01				Beschichtung
					4-18	1,92	1,92				Beschichtung
					4-19	1,92	1,92				Beschichtung
					4-20	1,92	1,92				Beschichtung
					4-21	1,96	1,96				Beschichtung
					4-22	2,13	2,13				Beschichtung
					4-23	2,18	2,18				Beschichtung
					4-24	2,20	2,20				Beschichtung
					4-25	1,84	1,84				Beschichtung
					4-26	1,84	1,84				Beschichtung
					4-27	2,01	2,01				Beschichtung
					4-28	2,01	2,01				Beschichtung
					4-29	2,01	2,01				Beschichtung
					4-30	1,92	1,92				Beschichtung
					4-31	1,92	1,92				Beschichtung
					4-32	1,92	1,92				Beschichtung
					4-33	1,96	1,96				Beschichtung
					4-34	2,13	2,13				Beschichtung
					4-35	2,18	2,18				Beschichtung
					4-36	2,20	2,20				Beschichtung
					Stiegenhaus S1	31,97			31,97		Feinsteinzeug
					Aufzug S1	2,88			2,88		-
					Schleuse S1.1	9,07			9,07		Beschichtung
					Schleuse S1.2	18,02			18,02		Beschichtung
					E-Raum S1	22,07		22,07			Beschichtung
					Technik/Heizung S1	21,93		21,93			Beschichtung
					Keller S1	42,24			42,24		Beschichtung
					1-1	1,91	1,91				Beschichtung
					1-2	1,91	1,91				Beschichtung



TOP	TOP-Kategorie				Widmung	Fläche [m²]	NF [m²]	TF [m²]	VF [m²]	Gewerbe [m²]	Bodenbelag
	A	B	C	D							
					1-3	1,91	1,91				Beschichtung
					1-4	1,91	1,91				Beschichtung
					1-5	1,91	1,91				Beschichtung
					1-6	1,70	1,70				Beschichtung
					1-7	1,63	1,63				Beschichtung
					1-8	1,70	1,70				Beschichtung
					1-9	1,61	1,61				Beschichtung
					1-10	1,61	1,61				Beschichtung
					1-11	1,61	1,61				Beschichtung
					1-12	1,61	1,61				Beschichtung
					1-13	1,61	1,61				Beschichtung
					1-14	1,61	1,61				Beschichtung
					1-15	1,60	1,60				Beschichtung
					1-16	1,60	1,60				Beschichtung
					1-17	1,60	1,60				Beschichtung
					1-18	1,60	1,60				Beschichtung
					1-19	1,60	1,60				Beschichtung
					1-20	1,64	1,64				Beschichtung
					1-21	1,57	1,57				Beschichtung
					1-22	1,58	1,58				Beschichtung
					1-23	1,58	1,58				Beschichtung
					1-24	1,58	1,58				Beschichtung
					1-25	1,58	1,58				Beschichtung
					1-26	1,56	1,56				Beschichtung
					1-27	1,93	1,93				Beschichtung
					1-28	1,93	1,93				Beschichtung
					1-29	1,94	1,94				Beschichtung
					1-30	1,64	1,64				Beschichtung
					1-31	1,63	1,63				Beschichtung
					1-32	1,64	1,64				Beschichtung
					1-33	1,61	1,61				Beschichtung
					1-34	1,61	1,61				Beschichtung
					1-35	1,61	1,61				Beschichtung
					1-36	1,61	1,61				Beschichtung
					1-37	1,61	1,61				Beschichtung
					1-38	1,61	1,61				Beschichtung
					1-39	1,60	1,60				Beschichtung
					1-40	1,60	1,60				Beschichtung
					1-41	1,60	1,60				Beschichtung
					1-42	1,60	1,60				Beschichtung
					1-43	1,60	1,60				Beschichtung
					1-44	1,64	1,64				Beschichtung
					1-45	1,57	1,57				Beschichtung
					1-46	1,58	1,58				Beschichtung
					1-47	1,58	1,58				Beschichtung
					1-48	1,58	1,58				Beschichtung
					1-49	1,58	1,58				Beschichtung
					1-50	1,56	1,56				Beschichtung
					FM-S1	41,82	41,82				Beschichtung
					Stiegenhaus P1	27,49			27,49		Feinsteinzeug
					Aufzug P1	2,88			2,88		-
					Schleuse P1.1	21,86			21,86		Beschichtung
					Schleuse P1.2	10,46			10,46		Beschichtung
					E-Raum P1	20,07		20,07			Beschichtung
					Technik/Heizung P1	22,57		22,57			Beschichtung
<b>UG</b>	<b>0</b>	<b>0</b>	<b>0</b>	<b>0</b>		<b>6.207,71</b>	<b>5.145,67</b>	<b>609,27</b>	<b>436,67</b>	<b>0,00</b>	



## STEIN GÖTTER HOF

LEBENSQUALITÄT FINDET STADT

DR. WILHELM  
STEINGÖTTER-STRASSE 25  
3107 ST. PÖLTEN

### STIEGE 1 / EG / TOP G-1

Gewerbefläche 235,29 m<sup>2</sup>

Freifläche 96,22 m<sup>2</sup>

01 Geschäft	171,35 m <sup>2</sup>	06 WC/WR H	4,22 m <sup>2</sup>
02 Küche	22,13 m <sup>2</sup>	07 WC Personal	2,64 m <sup>2</sup>
03 Lager	21,30 m <sup>2</sup>	08 Schleuse	2,95 m <sup>2</sup>
04 Garderobe	4,97 m <sup>2</sup>	09 Freifläche	96,22 m <sup>2</sup>
05 WC/WR D	5,73 m <sup>2</sup>		

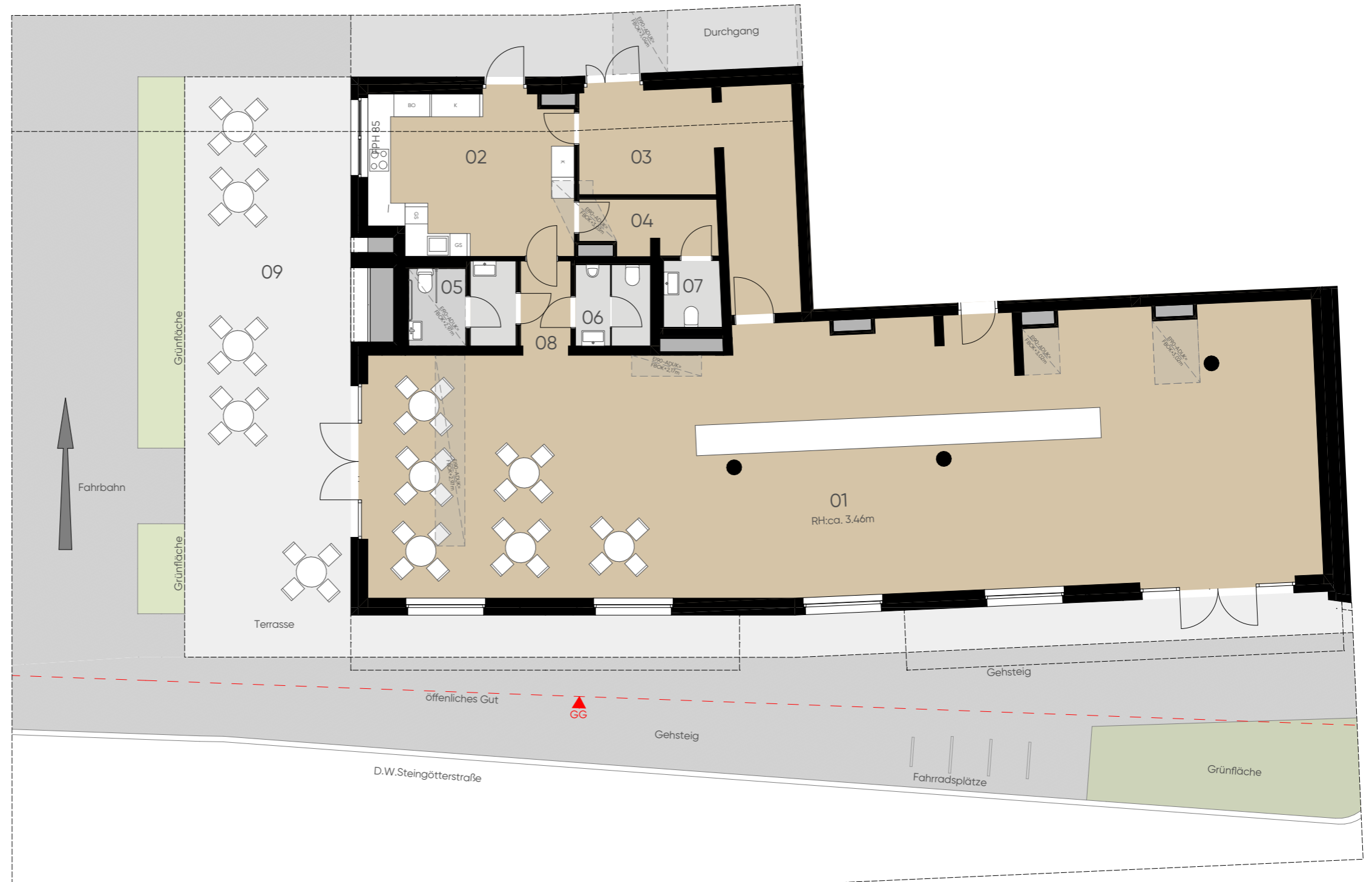
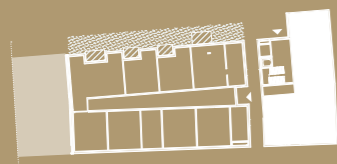
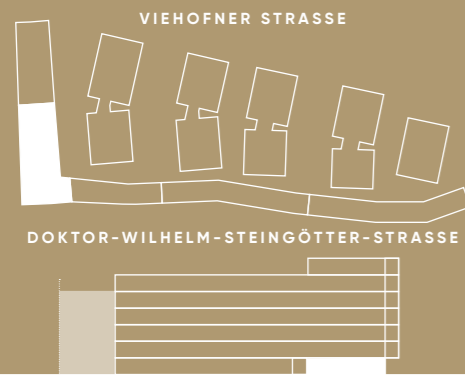

### ERDGESCHOSS

Die dargestellten Einrichtungsgegenstände dienen nur zur Illustration und sind nicht im Lieferumfang enthalten. Es gilt die Bau- und Ausstattungsbeschreibung. Sämtliche Maße sind Rohbaumaße. Naturmaße können abweichen. Planliche und bauliche Änderungen vorbehalten. Stand: 11.08.2021

0 5 10 15m

**6B47**  
REAL ESTATE INVESTORS

# STEIN GÖTTER HOF

LEBENSQUALITÄT FINDET STADT

DR. WILHELM  
STEINGÖTTER-STRASSE 25  
3107 ST. PÖLTEN

STIEGE 2 / EG / TOP G-2

Gewerbefläche 153,24 m<sup>2</sup>

Freifläche 20,74 m<sup>2</sup>

01 Geschäft	140,84 m <sup>2</sup>	04 AR	1,17 m <sup>2</sup>
02 Umkleide	8,91 m <sup>2</sup>	05 Freifläche	20,74 m <sup>2</sup>
03 WC	2,32 m <sup>2</sup>		

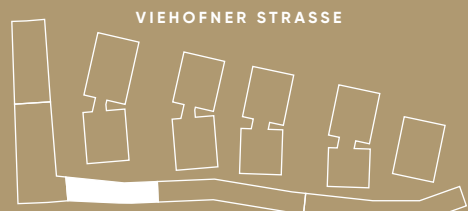

DOKTOR-WILHELM-STEINGÖTTER-STRASSE

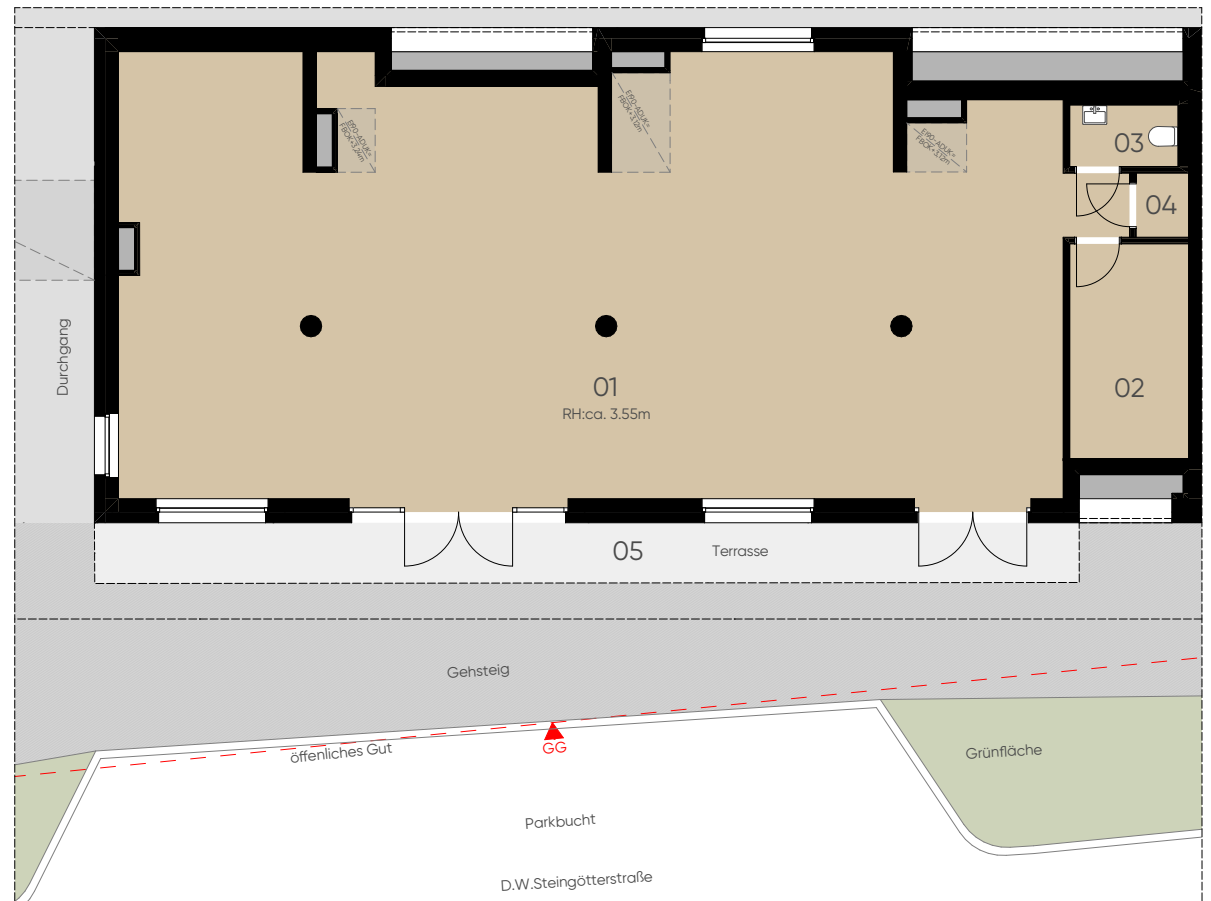

## ERDGESCHOSS



Die dargestellten Einrichtungsgegenstände dienen nur zur Illustration und sind nicht im Lieferumfang enthalten. Es gilt die Bau- und Ausstattungsbeschreibung. Sämtliche Maße sind Rohbaumaße. Naturmaße können abweichen. Planliche und bauliche Änderungen vorbehalten. Stand: 11.08.2021

**6B47**  
REAL ESTATE INVESTORS

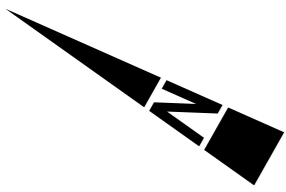

M 1:200

Projekt: <b>St. Pölten, Steingötterhof</b>	Planinhalt: <b>BF1 - Stg1+3 - EG - Terrassen&amp;Garten Zuteilung</b>	Plan-Nr.: 1876-Y-N-G- <b>003</b>	Datum: <b>07.09.2021</b>
---	--	--	-----------------------------

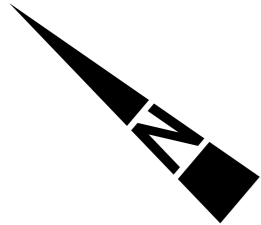

M 1:200

Projekt:  
**St. Pölten, Steingötterhof**

Planinhalt:  
**BF1 - Stg4 - EG - Terrassen & Garten Zuteilung**

Plan-Nr.:  
1876-Y-N-G-  
**004**

Datum:  
**07.09.2021**

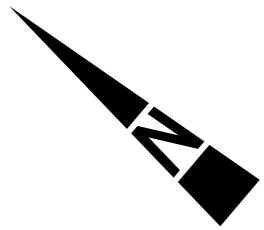

M 1:200

Projekt:

St. Pölten, Steingötterhof

Planinhalt:

BF1 - Stg1 - OG5 - Terrassen Zuteilung

Plan-Nr.:

1876-Y-N-G-  
008

Datum:

13.09.2021

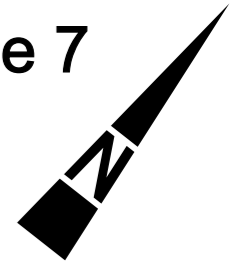

Stand Einreichung (S2-7)

Top 177	
Wohnräume	69,44 m <sup>2</sup>
Loggia	11,44 m <sup>2</sup>
SUMME	80,88 m <sup>2</sup>

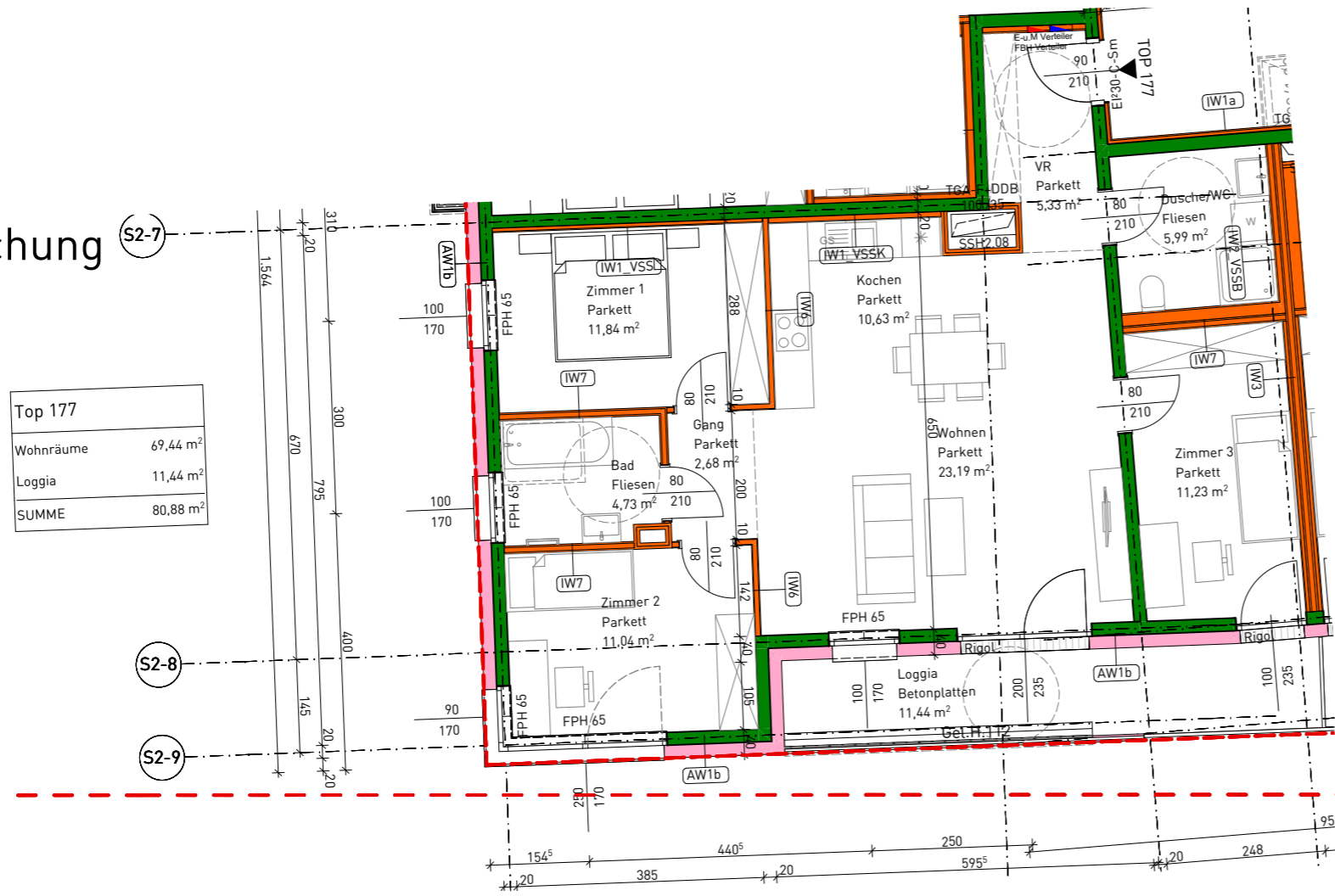

Stand Verkaufspläne (S2-7)

Top 177	
Wohnräume	86,70 m <sup>2</sup>
SUMME	86,70 m <sup>2</sup>
Terrasse	11,28 m <sup>2</sup>

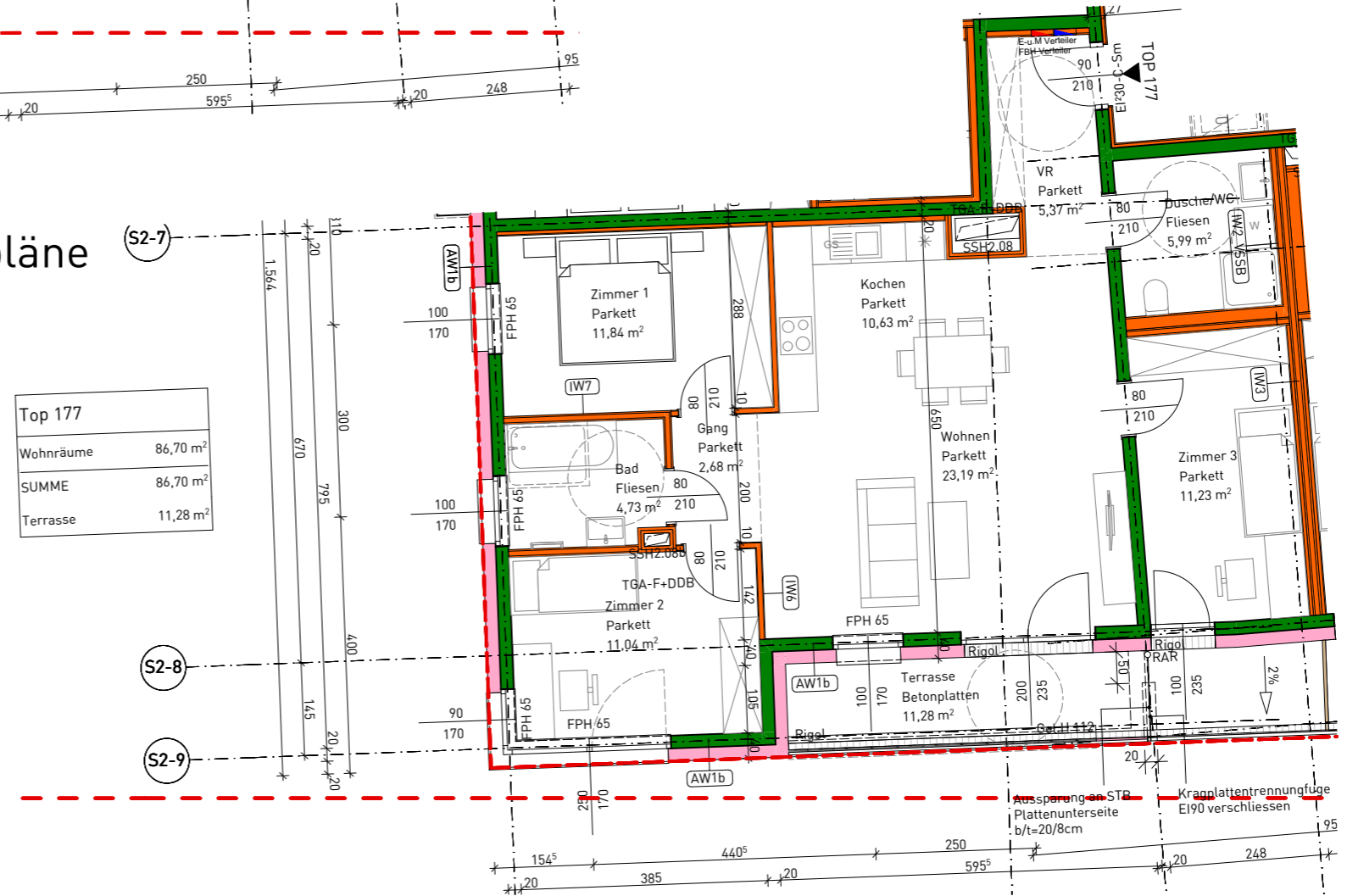

M 1:100

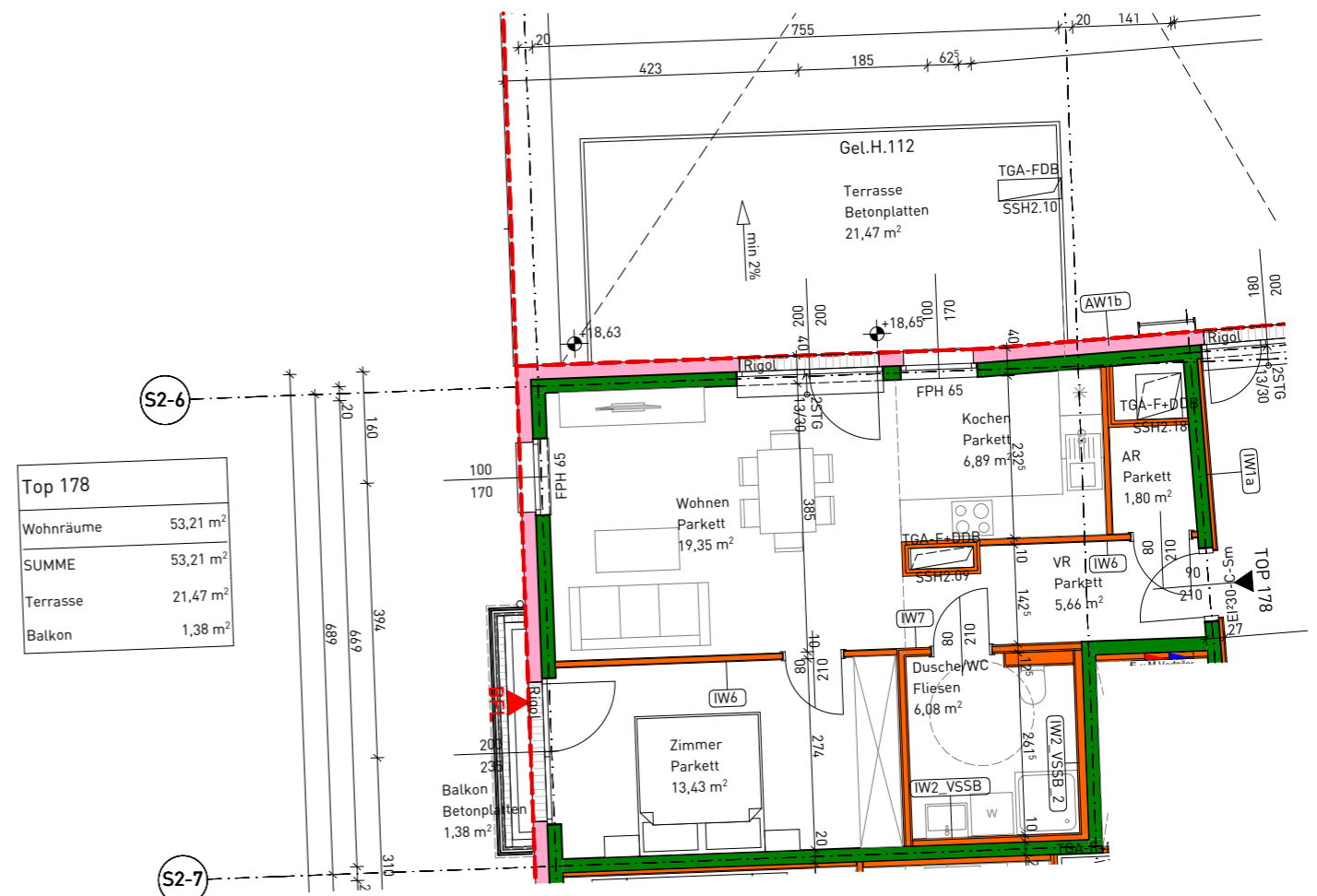
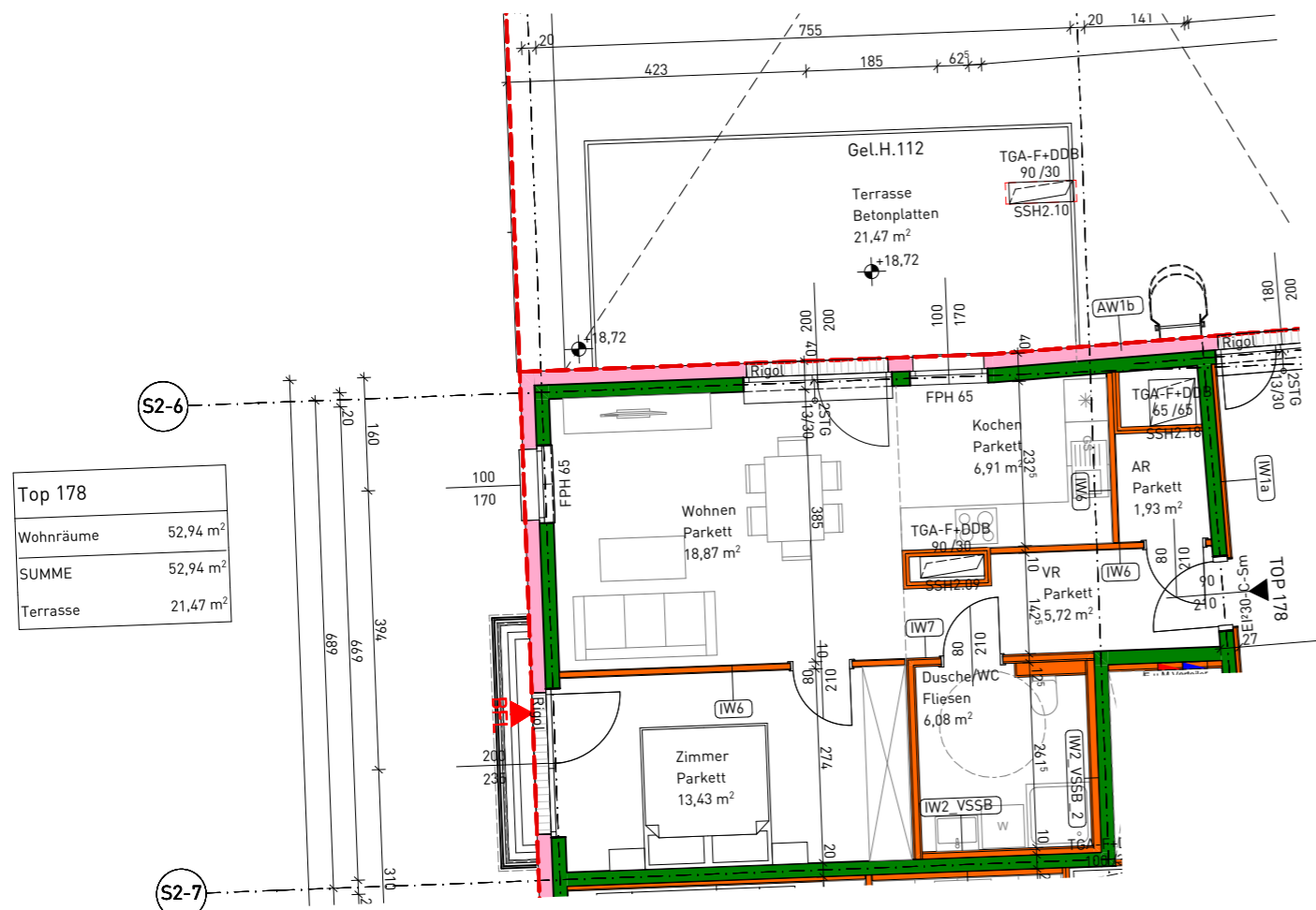
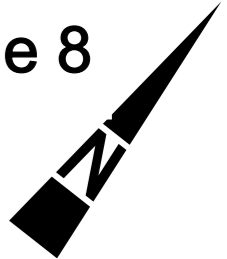

M 1:100

Projekt:

St. Pölten, Steingötterhof

Planinhalt:

BF1 - OG6 - Top 178

Plan-Nr.:

1876-Y-N-G-  
006

Datum:

07.09.2021



# STEIN GÖTTER HOF

LEBENSQUALITÄT FINDET STADT

DR. WILHELM  
STEINGÖTTER-STRASSE 25  
3107 ST. PÖLTEN

## STIEGE 1 / 5.OG / TOP 174

Wohnfläche	94,11 m <sup>2</sup>		
Balkon	7,20 m <sup>2</sup>		
Terrasse 1	19,16 m <sup>2</sup>	Terrasse 2	55,30 m <sup>2</sup>
01 Wohnküche	30,12 m <sup>2</sup>	07 Vorraum	13,04 m <sup>2</sup>
02 Zimmer 1	13,76 m <sup>2</sup>	08 Gang	1,79 m <sup>2</sup>
03 Zimmer 2	11,73 m <sup>2</sup>	09 Dusche	3,33 m <sup>2</sup>
04 Zimmer 3	11,79 m <sup>2</sup>	10 Balkon	6,82 m <sup>2</sup>
05 Bad	6,33 m <sup>2</sup>	11 Terrasse 1	19,16 m <sup>2</sup>
06 WC	2,22 m <sup>2</sup>	12 Terrasse 2	55,30 m <sup>2</sup>

VIEHOFNER STRASSE



DOKTOR-WILHELM-STEINGÖTTER-STRASSE

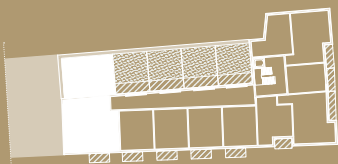
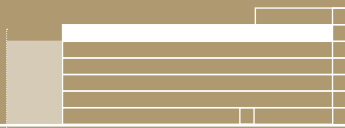

## Beilage 9



### 5. OBERGESCHOSS

Die dargestellten Einrichtungsgegenstände dienen nur zur Illustration und sind nicht im Lieferumfang enthalten. Es gilt die Bau- und Ausstattungsbeschreibung. Sämtliche Maße sind Rohbaumaße. Naturmaße können abweichen. Planliche und bauliche Änderungen vorbehalten. Stand: 11.08.2021



**6B47**  
REAL ESTATE INVESTORS